

2 - Entry Table

CODE	DESCRIPTION
120305	MICRO SWITCH WITH LEVER
160127	DRAIN HOSE D.40
170447	PINION Z=7 P60
180823	FILTER FOR ENTRY BRACKET
190653	LOOSE WHEEL BUSH ENTRY BRACKET
190906	CURTAIN IN/OUT 620X480
190930	CURTAIN ENTRY BTM/NE-2
200412	GASKET DRAIN 11/2" 45X33X3
200809	OR GASKET 1,78X8,73X12,29
210202	RUBBER FOOT GLASSWASHER
260127	SCREW TE 8X45
260208	SCREW TCP 4X30
260406	NUT 8MA
260418	SELF-LOCKING NUT M4
260505	STAINL.STEEL FLAT WASHER D8
260513	GROWER WASHER D8
270101	HEXAGON LOCK NUT 1/2"
322981	DOOR INSPECTION NE
330201	ROD FOR BELT ADJUSTING "N"
332114	BUSH FOR ECONOMISER
340624	PANEL (340633)
341242	LEVER
342061	BELT SPINDLE NE2
342097	SHAFT
370218	RINSE ECONOMISER FOR NE02
380110	BRASS BEARING D12 F.ECON.N
381001	LOCKING NUT FOR ECONOMIZER N
381101	PLATE
440208	FOOT INSERT
440209	COMPLETE FOOT NE
440907	SIPHON 1"1/2
440914	BASKET DRAIN OUTLET 1"1/2
440915	STRAINER
441503	LOCKING
450107	CLAMP FE ZN 38-50 H=12,2
451102	RINSE GATE PIN 3X26
460502	GASKET 30X21X2
510216	N RINSE GATE ECCENTRE
510511	SUPPORT FOR AXLE

3 - Prewash tank components 900mm

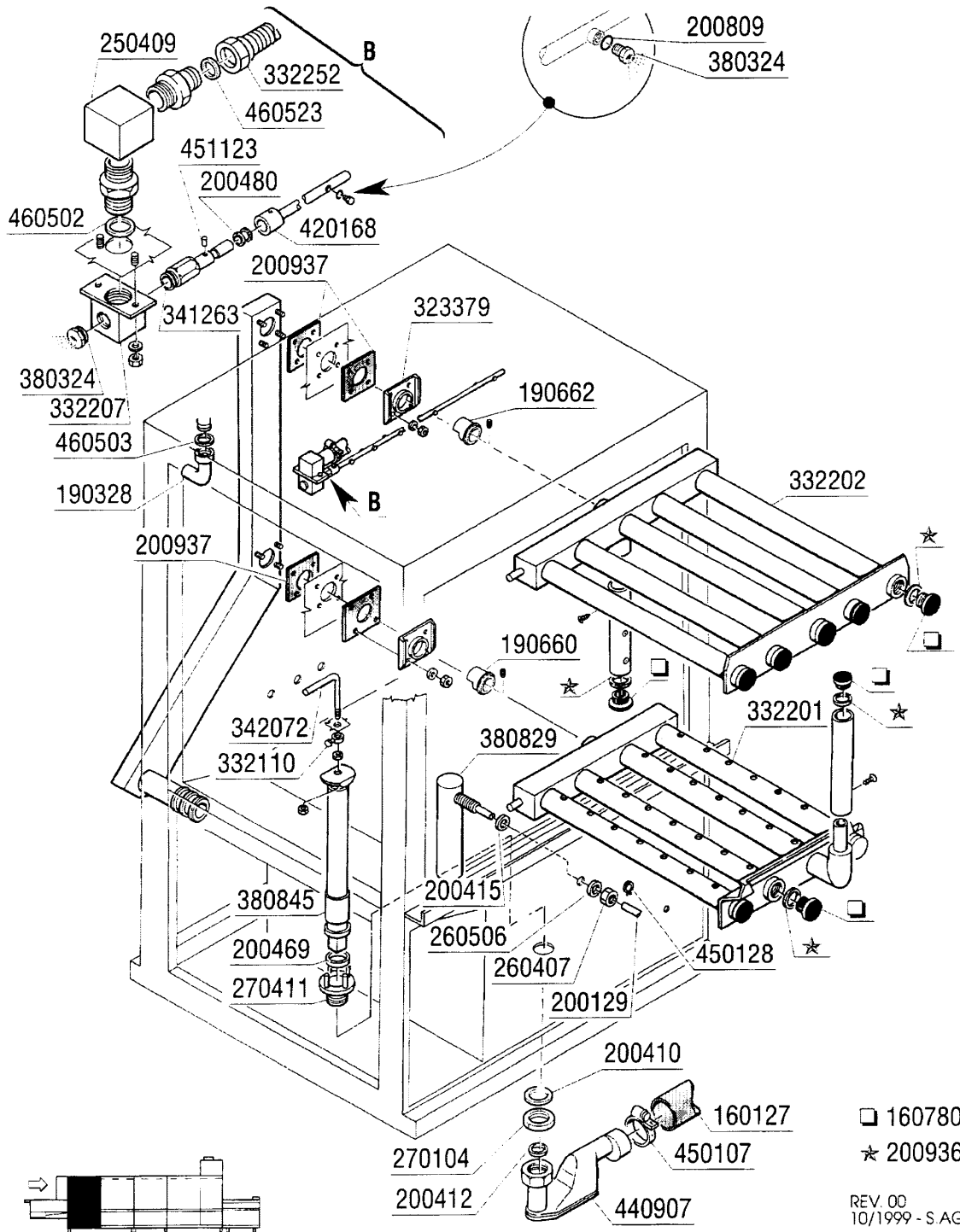

3 - Prewash tank components 900mm

CODE	DESCRIPTION
160127	DRAIN HOSE D.40
160780	PLUG FOR WASH ARM
190328	DRAIN 3/4"
190660	BUSH
190662	BUSH
200129	HOSE 5X11 FOR PRESSURE SWITCH
200410	DRAIN OUTL.WASH.1 1/2"65X47X2
200412	GASKET DRAIN 11/2" 45X33X3
200415	AIR TRAP GASKET -F2 18,5X10X3
200469	STAND PIPE O RING 45X35,5X7
200480	GASKET F. RINSE CONNECT.
200809	OR GASKET 1,78X8,73X12,29
200936	GASKET
200937	GASKET F.LOWER WASH ARM
250409	INOX ELL FF 1/2"
260407	STAINLESS STEEL NUTS D10 UNI 5
260506	STAINL.STEEL FLAT WASHER D10
270104	LOCK NUT 1" 1/2
270411	DRAIN OUTLET F. PREWASH/ECOR.
323379	HOOK FOR WASH MANIFOLD
332110	CLAMPING PIECES
332201	CONNECTION ELBOW F.LOWER WASH
332202	CONNECTION ELBOW F.UPPER WASH
332207	NIPPLE
332252	HOSE 1/2"-220X420-
341263	PIN
342072	PREWASH ROD NE02
380324	RINSE JETS 52,5 80Ø OV1/8"
380829	ST/ST AIR CHAMBER FOR NG-NE
380845	OVERFLOW PIPE PREWASH TANK NEO
420168	WASH ARM FOR SELF CLEANING
440907	SIPHON 1"1/2
450107	CLAMP FE ZN 38-50 H=12,2
450128	CLAMP
451123	ELASTIC PIN 4X16
460502	GASKET 30X21X2
460503	SEALING WASHER 38X27X2(3/4)
460523	GASKET 10X18X2

4 - Prewash Tank 900mm

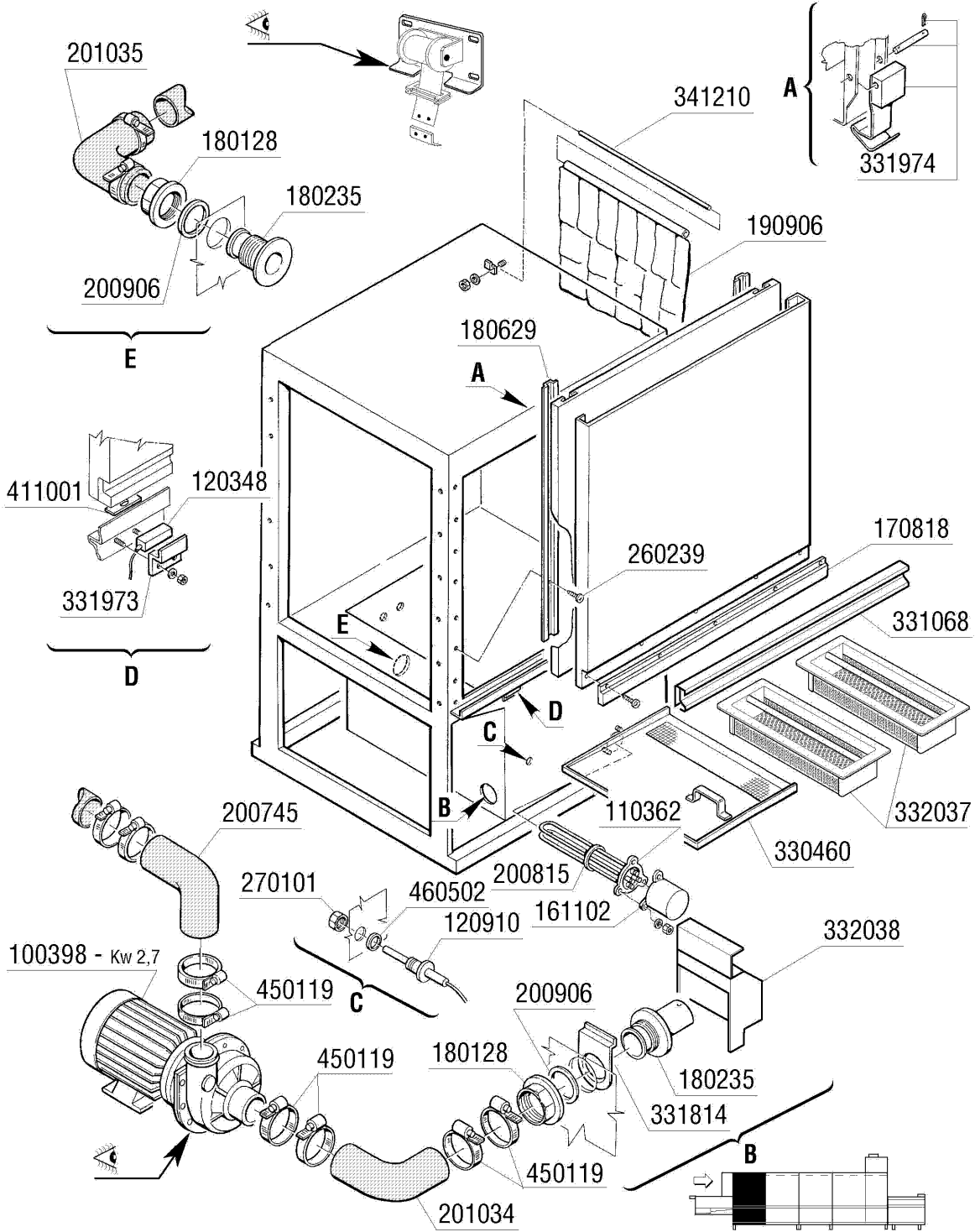

NOTE: _____

REV. 01
06/2001 - S.A.G.

4 - Prewash Tank 900mm

CODE	DESCRIPTION
100398	PUMP HP 3,7 220/380/50-2275
110362	HEAT.ELEMENT 9000W 220/380V
120348	MAGN.SWITCH (N.O.)
120910	ELECTRONIC TOUCH PAD CONTROLS
161102	ELEMENT COVER MOPL.
170818	SUPPORT FOR HANDLE 900 NE
180128	RING NUT 65,4 C140 C85
180235	PUMP SUCTION C85-140
180629	DOUBLE SKINNED DOOR RUNNER -NE
190906	CURTAIN IN/OUT 620X480
200745	INLET HOSE WASH. SNL
200815	O-RING F. HEAT.ELEM.
200906	GASKET D.92X66X2
201034	WASH TANK INLET HOSE
201035	TANK HOSE CLAMP
260239	SPECIAL S/S TB-SCREWS M6X20
270101	HEXAGON LOCK NUT 1/2"
330460	WASH STRAINER
331068	DOOR HANDLE 900 NE02
331814	BRACKET FOR FILTER C95-C155
331973	DOOR MICRO SWITCH BRACKET
331974	SUPPORT FOR DOOR HOOK
332037	900 PREWASH STRAINER NE2
332038	FILTER FOR PUMP
341210	CURTAIN SHAFTS N 2S GM
411001	PERMANENT MAGNET 8X40
450119	CLAMP FE ZN. 58-75 H=12,2
460502	GASKET 30X21X2

5 - Wash Tank Components 900mm

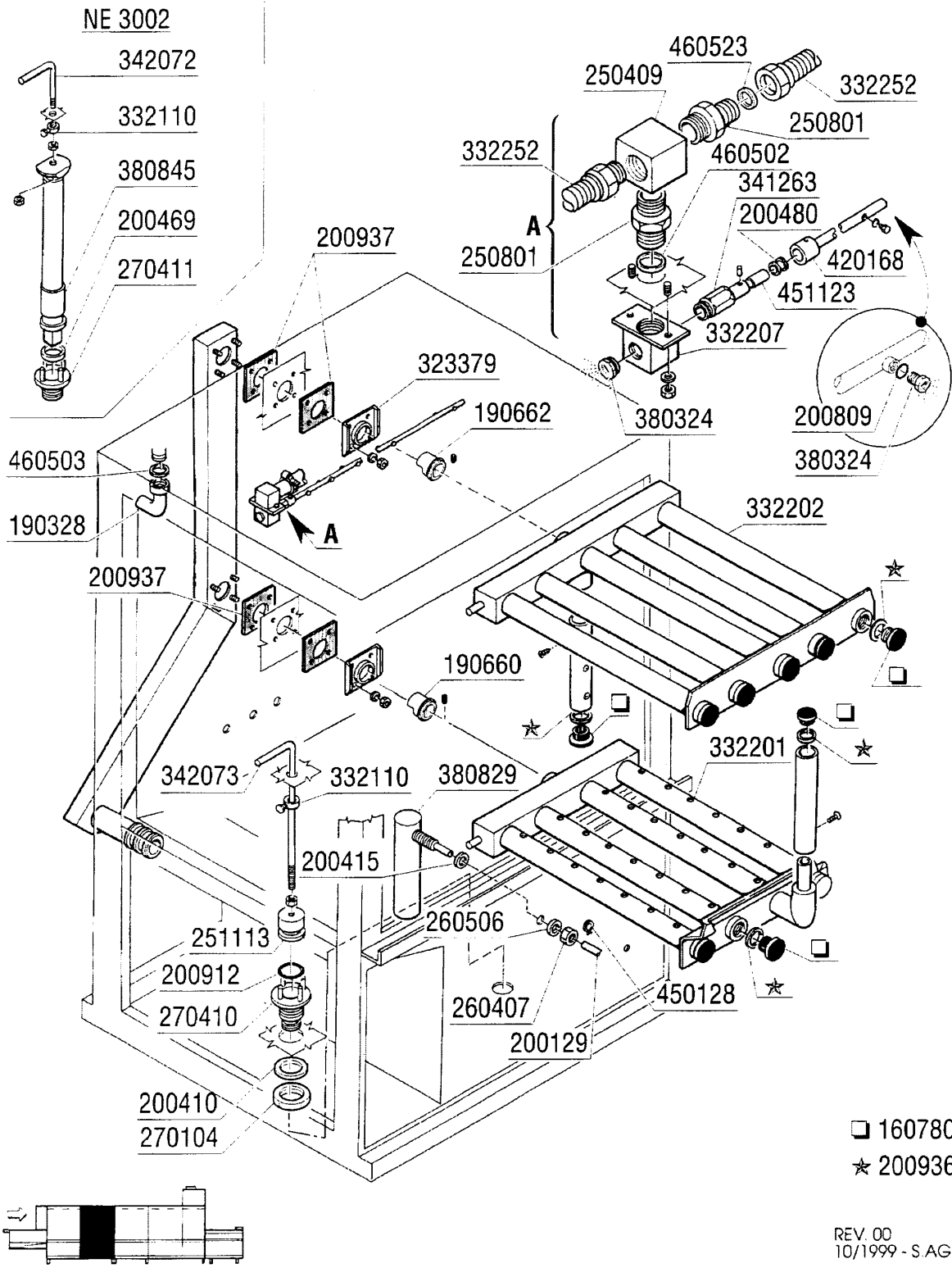

5 - Wash Tank Components 900mm

CODE	DESCRIPTION
160780	PLUG FOR WASH ARM
190328	DRAIN 3/4"
190660	BUSH
190662	BUSH
200129	HOSE 5X11 FOR PRESSURE SWITCH
200410	DRAIN OUTL.WASH.1 1/2"65X47X2
200415	AIR TRAP GASKET -F2 18,5X10X3
200469	STAND PIPE O RING 45X35,5X7
200480	GASKET F. RINSE CONNECT.
200809	OR GASKET 1,78X8,73X12,29
200912	GASKET ECORINSE OVERFLOW PIPE
200936	GASKET
200937	GASKET F.LOWER WASH ARM
250409	INOX ELL FF 1/2"
250801	NIPPLES 1/2" INOX
251113	PLUG FOR DRAIN TANK
260407	STAINLESS STEEL NUTS D10 UNI 5
260506	STAINL.STEEL FLAT WASHER D10
270104	LOCK NUT 1" 1/2
270410	TANK DRAIN OUTLET
270411	DRAIN OUTLET F. PREWASH/ECOR.
323379	HOOK FOR WASH MANIFOLD
332110	CLAMPING PIECES
332201	CONNECTION ELBOW F.LOWER WASH
332202	CONNECTION ELBOW F.UPPER WASH
332207	NIPPLE
332252	HOSE 1/2"-220X420-
341263	PIN
342072	PREWASH ROD NE02
342073	WASH ROD
380324	RINSE JETS 52,5 80Ø OV1/8"
380829	ST/ST AIR CHAMBER FOR NG-NE
380845	OVERFLOW PIPE PREWASH TANK NE0
420168	WASH ARM FOR SELF CLEANING
450128	CLAMP
451123	ELASTIC PIN 4X16
460502	GASKET 30X21X2
460503	SEALING WASHER 38X27X2(3/4)
460523	GASKET 10X18X2

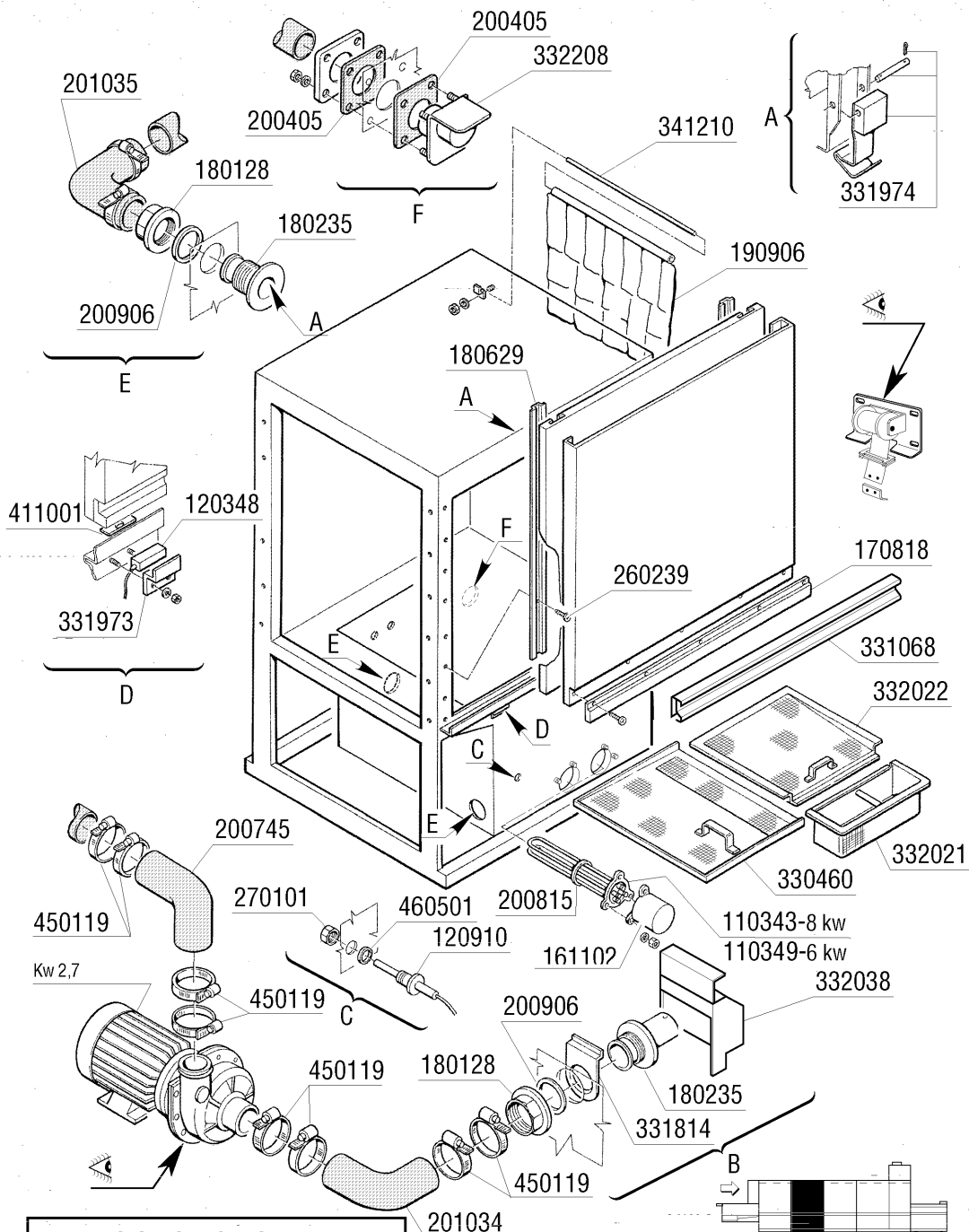

VALIDO SINO A OTTOBRE 2002
 VALID UP TO OCTOBER 2002

02-2005 S. AG.

6 - Wash tank 900mm

CODE	DESCRIPTION
110343	HEAT.ELEM. 8000W 220/380V
110349	HEAT.ELEMENT 6000W 230/400V
120348	MAGN.SWITCH (N.O.)
120910	ELECTRONIC TOUCH PAD CONTROLS
161102	ELEMENT COVER MOPL.
170818	SUPPORT FOR HANDLE 900 NE
180128	RING NUT 65,4 C140 C85
180235	PUMP SUCTION C85-140
180629	DOUBLE SKINNED DOOR RUNNER -NE
190906	CURTAIN IN/OUT 620X480
200405	GASKET 110X100X63 IN NEOTEN
200745	INLET HOSE WASH. SNL
200815	O-RING F. HEAT.ELEM.
200906	GASKET D.92X66X2
201034	WASH TANK INLET HOSE
201035	TANK HOSE CLAMP
260239	SPECIAL S/S TB-SCREWS M6X20
270101	HEXAGON LOCK NUT 1/2"
330460	WASH STRAINER
331068	DOOR HANDLE 900 NE02
331814	BRACKET FOR FILTER C95-C155
331973	DOOR MICRO SWITCH BRACKET
331974	SUPPORT FOR DOOR HOOK
332021	FILTER DRAWER
332022	FILTER ON SLIPWAY F.WASHING 90
332038	FILTER FOR PUMP
332208	SEE 332578
341210	CURTAIN SHAFTS N 2S GM
411001	PERMANENT MAGNET 8X40
450119	CLAMP FE ZN. 58-75 H=12,2
460501	GASKET 24X17X2

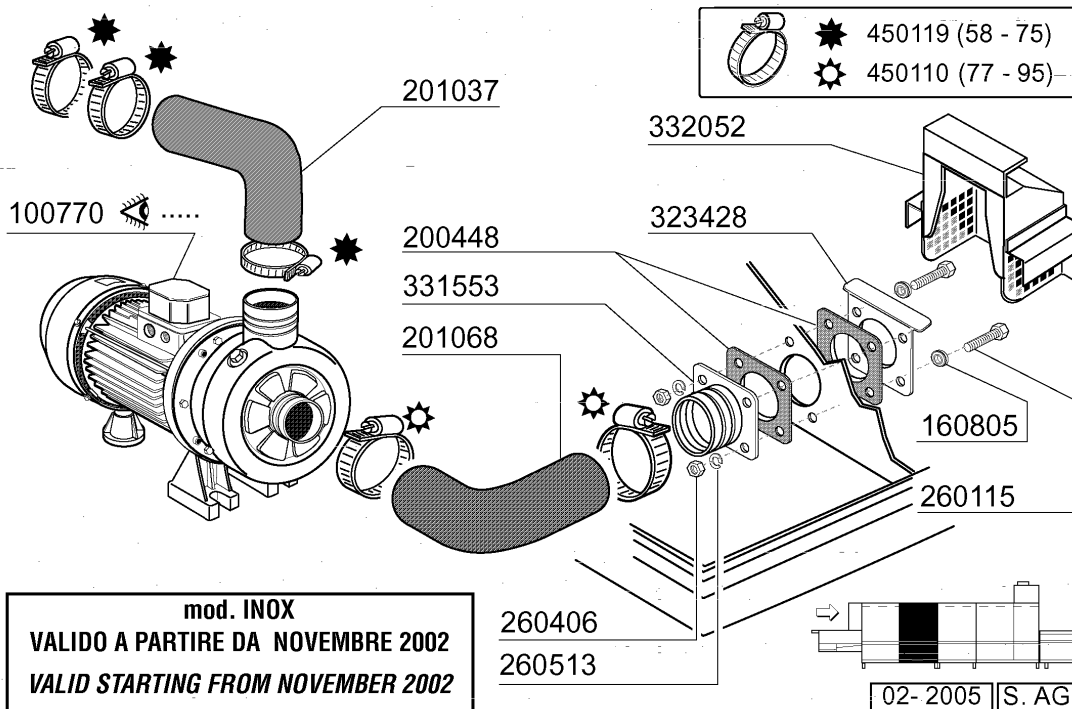
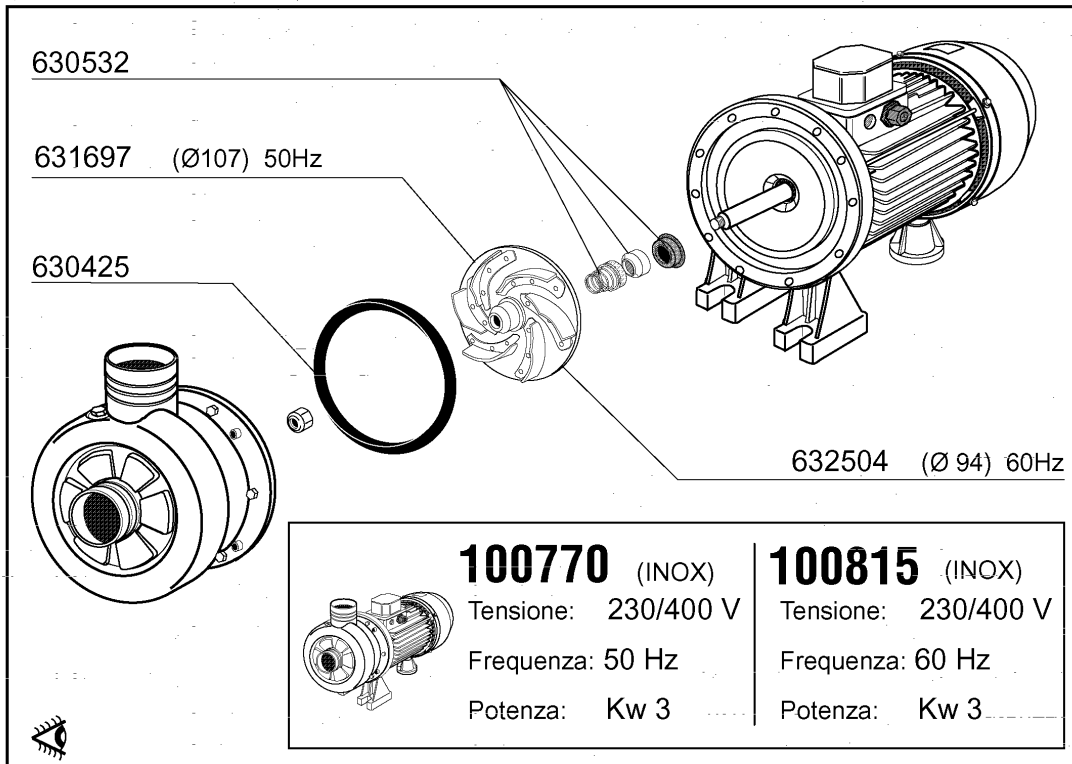

7 - Wash pump

CODE	DESCRIPTION
100770	PUMP 4HP EBARA
100815	PUMP 4HP 400/3/60
160805	GASKET D.8
200448	GASKET 100X100X3 HOLE D.76
201037	OUTLET HOSE
201068	SUCTION HOSE
260115	STAIN.ST.TE SCREW 8X20 A2 UNI
260406	NUT 8MA
260513	GROWER WASHER D8
323428	FILTER BRACKET
331553	INLET ELBOW FOR NG-GL WASH PUM
332052	SUCTION FILTER NG2
450110	HOSE CLAMP 77-95
450119	CLAMP FE ZN. 58-75 H=12,2
630425	GASKET FOR PUMP 100770/78
630532	SEAL FOR PUMP 100770/78
631697	IMPELLER FOR PUMP 100770
632504	GIRANTE DWO400/60 251450812

8 - Double rinse components

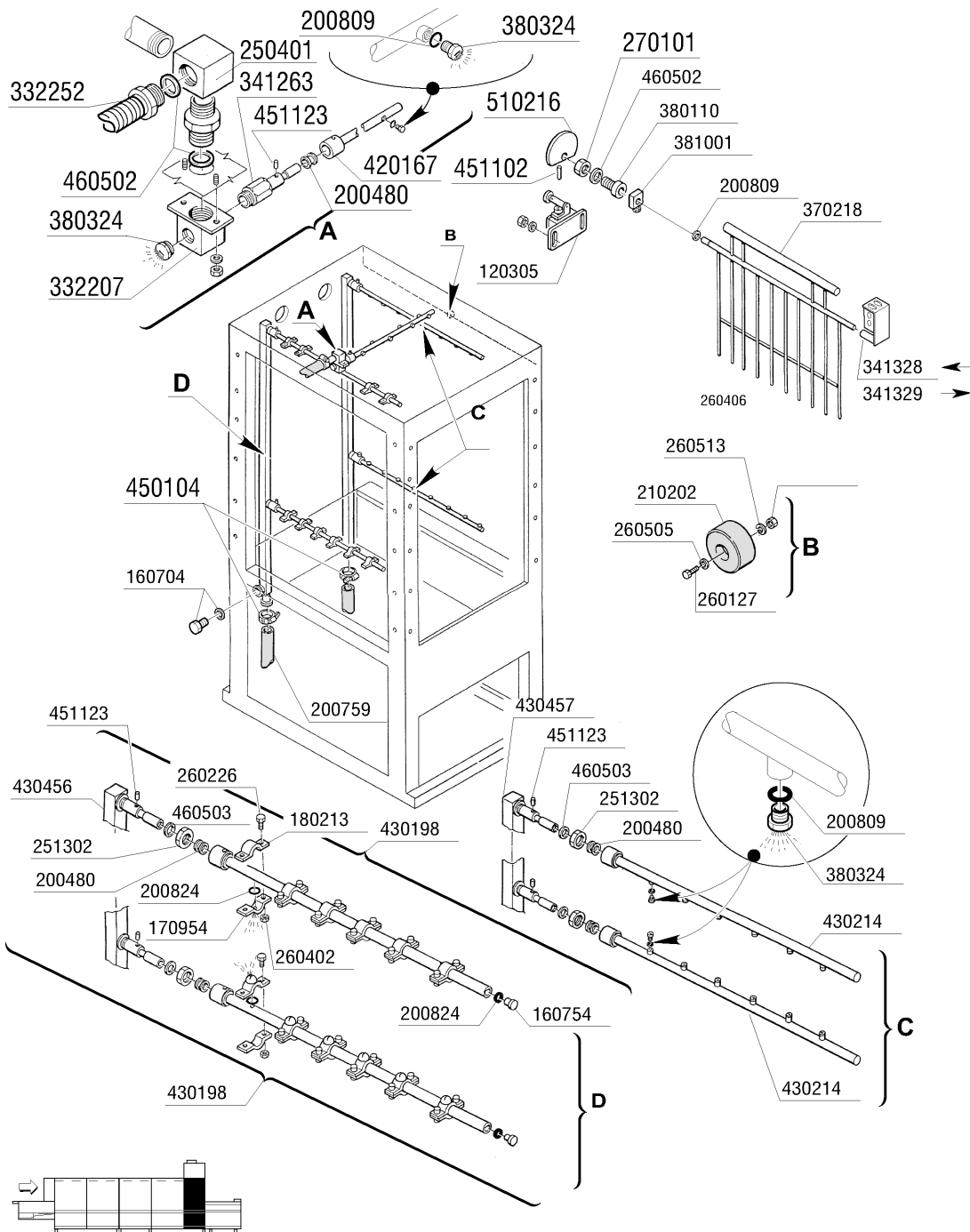

REV. 02
07/2008 - M.S.A.

NOTE: _____

8 - Doublr rinse components

CODE	DESCRIPTION
120305	MICRO SWITCH WITH LEVER
160704	BLACK PLUG WITH GASKET 1/2"GAK
160754	PLUG FOR RINSE ARMS SE NE
170954	JET FOR ECORINSE ARM
180213	FLANGE F.JET LOCKING F2-C34
200480	GASKET F. RINSE CONNECT.
200759	DELIVERY HOSE FOR ECORINSE AC-
200809	OR GASKET 1,78X8,73X12,29
200824	O-RING 1,78X12,42X15,98
210202	RUBBER FOOT GLASSWASHER
250401	INOX ELL FF 1/2"
251302	S/S LOCK NUT 3/4" AC-ACR
260127	SCREW TE 8X45
260226	STAINL.ST TCP SCREW 4X12 A2 UN
260402	STAINLESS STEEL NUT D4 UNI 55
260406	NUT 8MA
260505	STAINL.STEEL FLAT WASHER D8
260513	GROWER WASHER D8
270101	HEXAGON LOCK NUT 1/2"
332207	NIPPLE
332252	HOSE 1/2"-220X420-
341263	PIN
341328	SUPPORT (341846)
341329	SUPPORT (341846)
370218	RINSE ECONOMISER FOR NE02
380110	BRASS BEARING D12 F.ECON.N
380324	RINSE JETS 52,5 80Ø OV1/8"
381001	LOCKING NUT FOR ECONOMIZER N
420167	WASH ARM FOR SELF CLEANING
430198	ECORINSE ARM NE02
430214	RINSE ARM NE02
430456	ECPRINSE COLUMN NE02
430457	RINSE COLUMN NE02
450104	CLAMP FE ZN H=12,5 15-24
451102	RINSE GATE PIN 3X26
451123	ELASTIC PIN 4X16
460502	GASKET 30X21X2
460503	SEALING WASHER 38X27X2(3/4)
510216	N RINSE GATE ECCENTRE

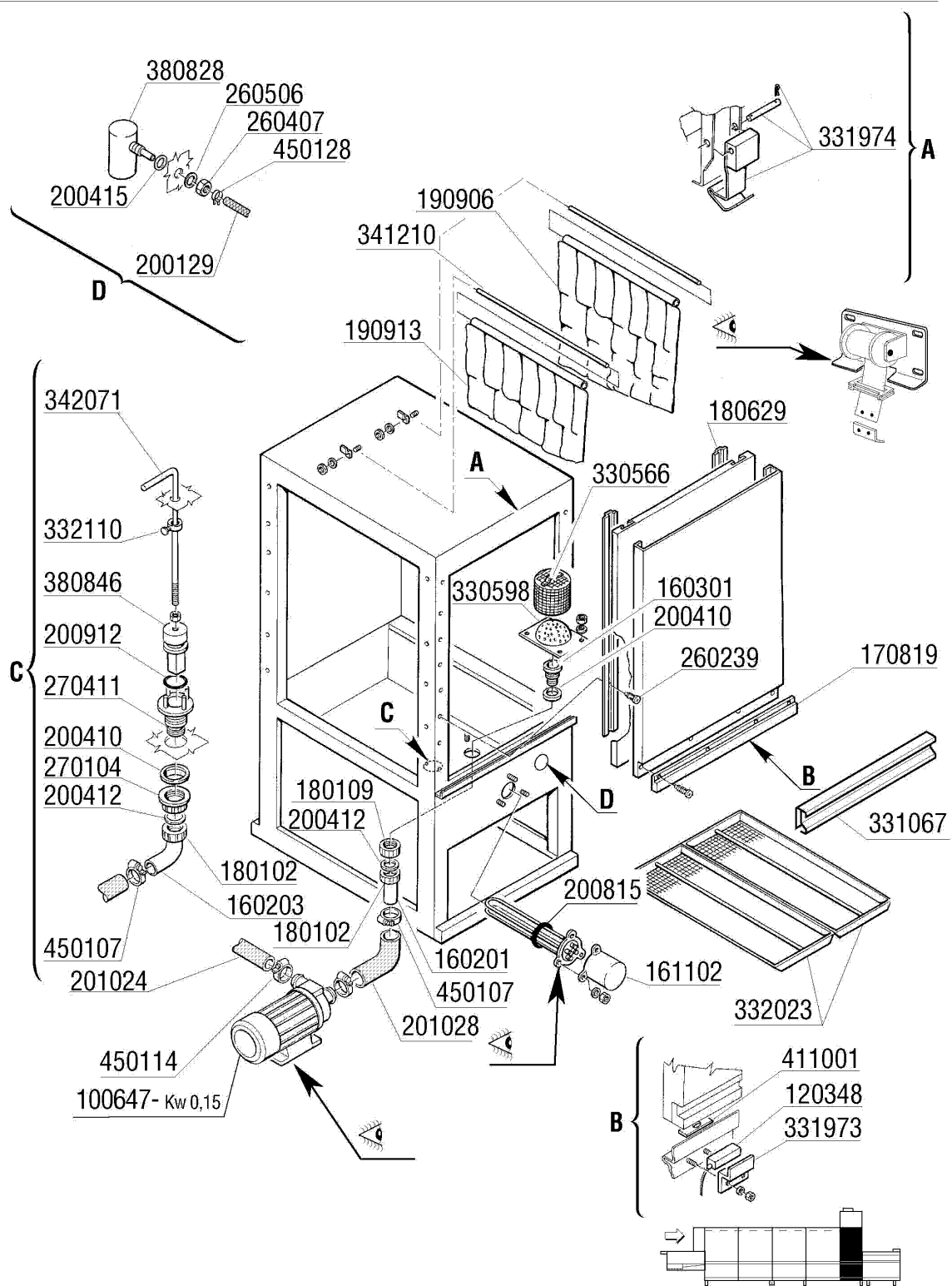

NOTE: _____

REV. 01
06/2001 - S.A.G.

9 - Double rinse tank

CODE	DESCRIPTION
100647	PUMP HP 0,20 220/240/3 4226
120348	MAGN.SWITCH (N.O.)
160201	ELBOW F.TANK INLET MOPLN
160203	ELBOW 1"1/2 N-S-F-C /DRAIN
160301	DRAIN OUTLET 1"1/2 C-S-N
161102	ELEMENT COVER MOPL.
170819	SUPPORT FOR HANDLE 600 NE
180102	DRAIN PIPE NUT 1"1/2 F45-55
180109	LOCK NUT 1 1/2"
180629	DOUBLE SKINNED DOOR RUNNER -NE
190906	CURTAIN IN/OUT 620X480
190913	CURTAIN FOR ECORINSE SE-620X27
200129	HOSE 5X11 FOR PRESSURE SWITCH
200410	DRAIN OUTL.WASH.1 1/2"65X47X2
200412	GASKET DRAIN 11/2" 45X33X3
200415	AIR TRAP GASKET -F2 18,5X10X3
200815	O-RING F. HEAT.ELEM.
200912	GASKET ECORINSE OVERFLOW PIPE
201024	ECOR.PUMP INLET HOSE AC (+2010
201028	OUTLET HOSE F. PREWASH 400MM A
260239	SPECIAL S/S TB-SCREWS M6X20
260407	STAINLESS STEEL NUTS D10 UNI 5
260506	STAINL.STEEL FLAT WASHER D10
270104	LOCK NUT 1" 1/2
270411	DRAIN OUTLET F. PREWASH/ECOR.
330566	FILTER 110 FOR ECORINSE TANK
330598	ECORINSE FILTER
331067	DOOR HANDLE 600 NE02
331973	DOOR MICRO SWITCH BRACKET
331974	SUPPORT FOR DOOR HOOK
332023	ECORINSE TANK FILTER
332110	CLAMPING PIECES
341210	CURTAIN SHAFTS N 2S GM
342071	ECORINSE ROD NE02
380828	ECORINSE AIR CHAMBER AC-ACR ST
380846	OVERFLOW PIPE ECORINSE TANK NE
411001	PERMANENT MAGNET 8X40
450107	CLAMP FE ZN 38-50 H=12,2
450114	CLAMP FE ZN.22-32 H=12,2
450128	CLAMP

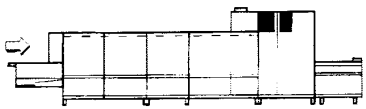
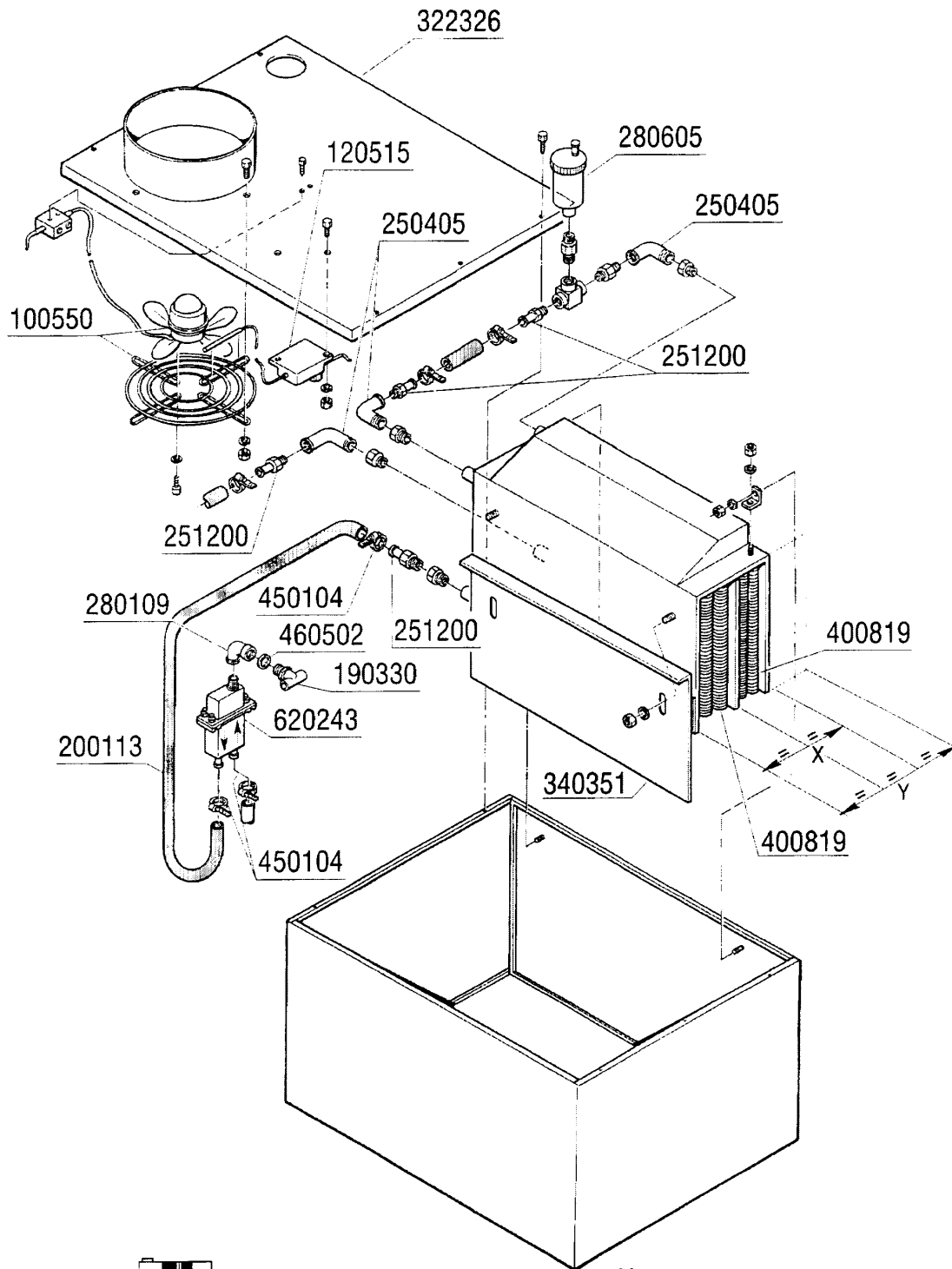

REV. 00
10/1999 - S. AG.

X= 370 mm = 40 mq = 2x400819
Y= 555 mm = 60 mq = 3x400819

10 - Heat recovery unit

CODE	DESCRIPTION
100550	FAN FOR HEAT RECOVERY UNIT
120515	THERMOSTAT 0-90°C
190330	TEE FOR VACUUM BREAKER
200113	RUBBER HOSE 12 X 22
250405	INOX ELL MF 1/2"
251200	S/S NIPPLE 1/2"
280109	CRANK 90° F.F 3/8"
280605	AUTOMATIC AIR VENT 1/4" GAS
322326	TOP PANEL
340351	PANEL
400819	HRU BATTERY
450104	CLAMP FE ZN H=12,5 15-24
460502	GASKET 30X21X2
620243	VACUUM BREAKER (WITHOUT KIT)

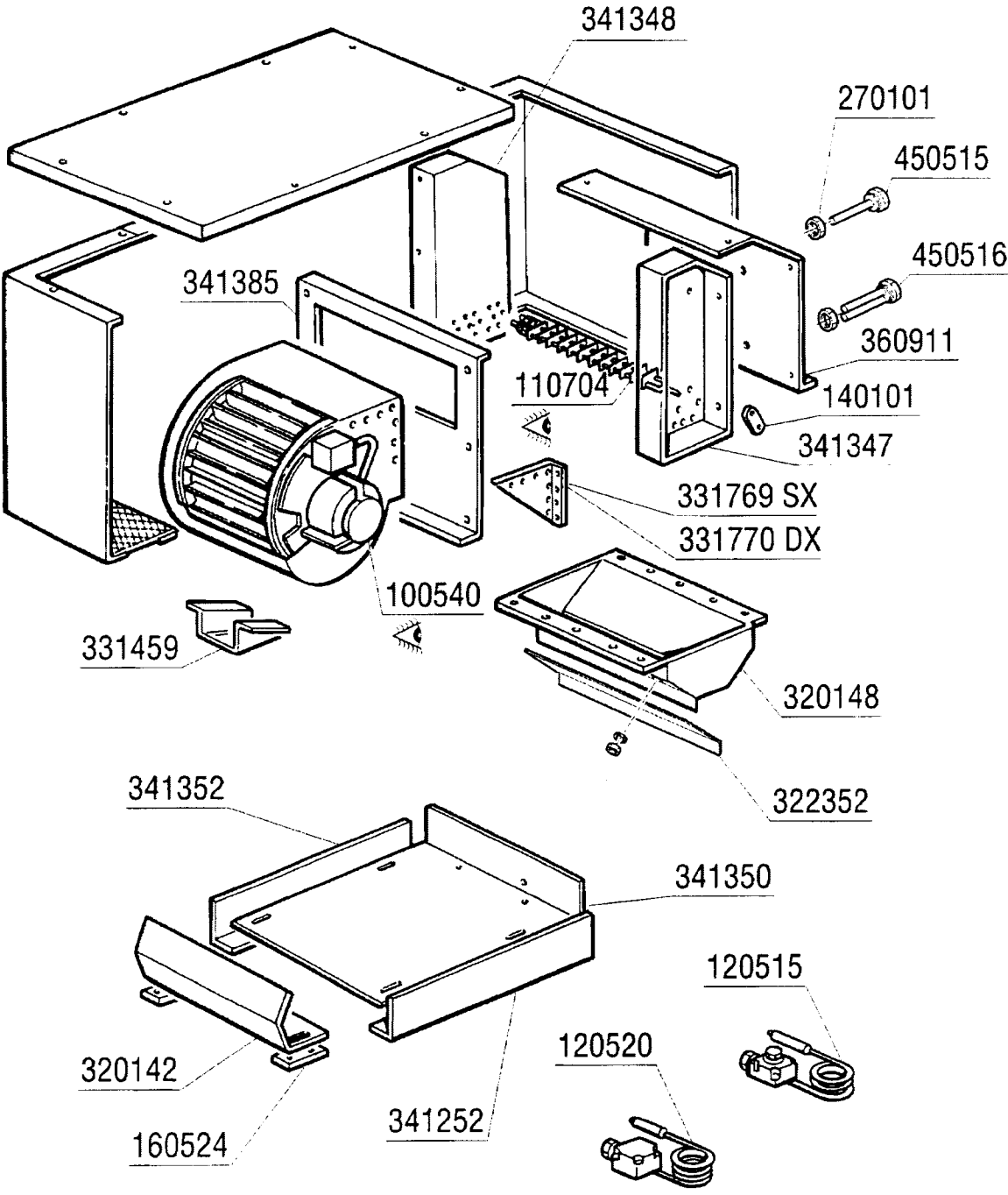

REV. 00
10/1999 - S.A.G.

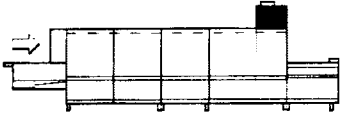

11 - Blower Dryer - electric version 800mm

CODE	DESCRIPTION
100540	NE DRYER FAN 2HP 220/380/50HZ
110704	HEAT.ELEMENT/DRYING 1000W 220V
120515	THERMOSTAT 0-90°C
120520	SECURITY THERMOSTAT 110-130°C
140101	BRASS CONNECT. PLATE HEAT.ELEM
160524	SPACER OF SHAFT SE
270101	HEXAGON LOCK NUT 1/2"
320142	DEFLECTOR F. DRYER
320148	DEFLECTOR F. DRYER
322352	BRACKET
331459	BRACKET FOR DRYING VENTILATOR
331769	ZIEHL FAN SUPPORT
331770	ZIEHL FAN SUPPORT
341252	PIN D.25
341347	RIGHT SUPPORT
341348	LEFT SUPPORT
341350	PANEL
341352	SUPPORT
341385	DRYER FAN SUPPORT FOR NE MACHI
360911	PANEL
450515	STAINL.ST.SHIELD FOR 1 THERMOS
450516	THERMOSTAT SHIELD FOR 2 TERMOS

12 - Blower Dryer 800mm

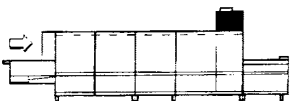
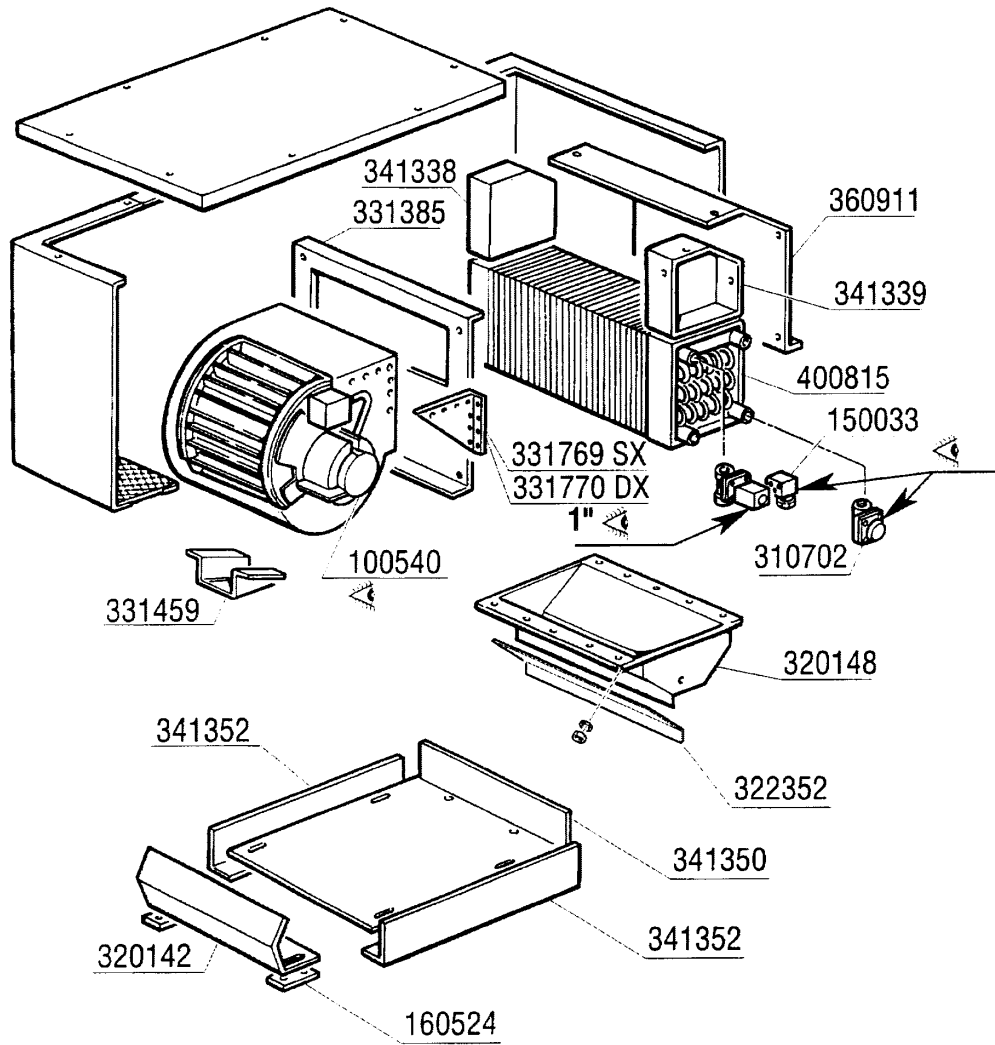

REV. 00
10/1999 - S.A.G.

12 - Blower Dryer 800mm

CODE	DESCRIPTION
100540	NE DRYER FAN 2HP 220/380/50HZ
150033	CONNEC.F.SOLEN.VALVE 182.09.N
160524	SPACER OF SHAFT SE
310702	STEAM TRAP 1/2" MK 25/3
320142	DEFLECTOR F. DRYER
320148	DEFLECTOR F. DRYER
322352	BRACKET
331385	PRE-RINSE HOSE
331459	BRACKET FOR DRYING VENTILATOR
331769	ZIEHL FAN SUPPORT
331770	ZIEHL FAN SUPPORT
341338	RIGHT PANEL
341339	LEFT PANEL
341350	PANEL
341352	SUPPORT
360911	PANEL
400815	BATTERY FOR DRYING (9-12KW) SE

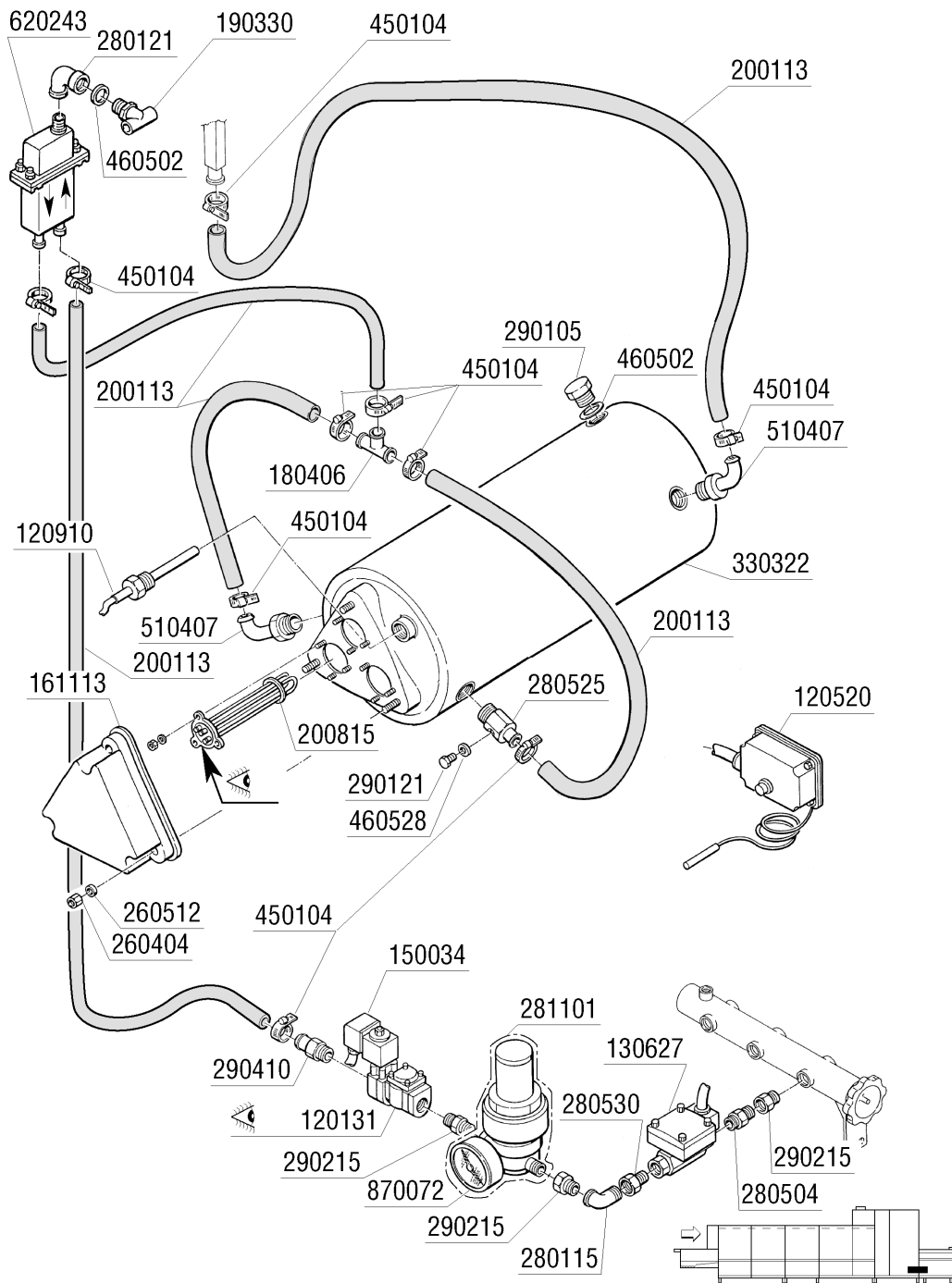

13 - Electric version

CODE	DESCRIPTION
120131	SOLE. L182Q31-ZB10A 1/2"24V
120520	SECURITY THERMOSTAT 110-130Ø
120910	ELECTRONIC TOUCH PAD CONTROLS
130627	FLUX CONTROL FS100E-A REG. 1/16
150034	CONNEC.F.SOLEN.VALVE 122.09.N
161113	ELMENT COVER BLACK
180406	T-CONNECTOR F. WASHING S90-SNL
190330	TEE FOR VAACUM BREAKER
200113	RUBBER HOSE 12 X 22
200815	O-RING F. HEAT.ELEM.
260404	STAINLESS STEEL NUTS D6 UNI 55
260512	ST/ST GROWER WASHER D6
280115	ELL 1/2"
280121	ELL FOR VAACUM BREAKER
280504	MANIFOLD CONN.HOSE
280525	NIPPLE
280530	CONNECT.3/4"X3/8"
281101	3/4" ADJ VALVE C/W GAUGE
290105	BRASS-TE-PLUG 1/2"
290121	BRASS PLUG 1/8"
290215	1/2"BSP M/F UNION BRASS
290410	NIPPLE 1/2"
330322	INSULATED BOILER D.230 N/S
450104	CLAMP FE ZN H=12,5 15-24
460502	GASKET 30X21X2
460528	GASKET 15X10X2 FOR RINSE NIPPE
510407	NIPPLE FOR BOILER N S
620243	VACUUM BREAKER (WITHOUT KIT)
870072	PRESSURE CAUGE 0-4 ATM

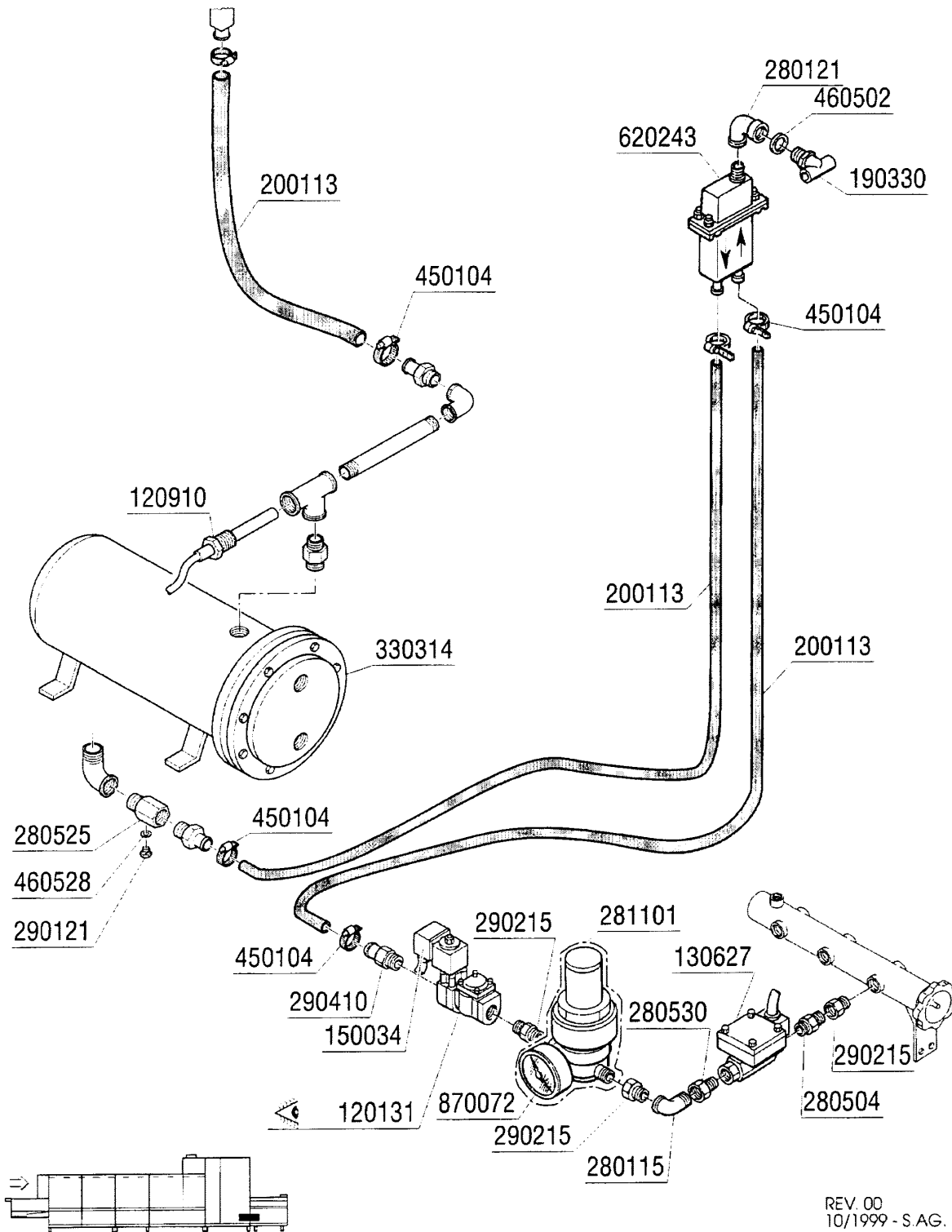

REV. 00
10/1999 - S.A.G.

14 - Steam version

CODE	DESCRIPTION
120131	SOLE. L182Q31-ZB10A 1/2"24V
120910	ELECTRONIC TOUCH PAD CONTROLS
130627	FLUX CONTROL FS100E-A REG.1/16
150034	CONNec.F.SOLEN.VALVE 122.09.N
190330	TEE FOR VAACUM BREAKER
200113	RUBBER HOSE 12 X 22
280115	ELL 1/2"
280121	ELL FOR VAACUM BREAKER
280504	MANIFOLD CONN.HOSE
280525	NIPPLE
280530	CONNECT.3/4"X3/8"
281101	3/4" ADJ VALVE C/W GAUGE
290121	BRASS PLUG 1/8"
290215	1/2"BSP M/F UNION BRASS
290410	NIPPLE 1/2"
330314	STEAM BOILER 30000 KCAL/H
450104	CLAMP FE ZN H=12,5 15-24
460502	GASKET 30X21X2
460528	GASKET 15X10X2 FOR RINSE NIPPE
620243	VACUUM BREAKER (WITHOUT KIT)
870072	PRESSURE CAUGE 0-4 ATM

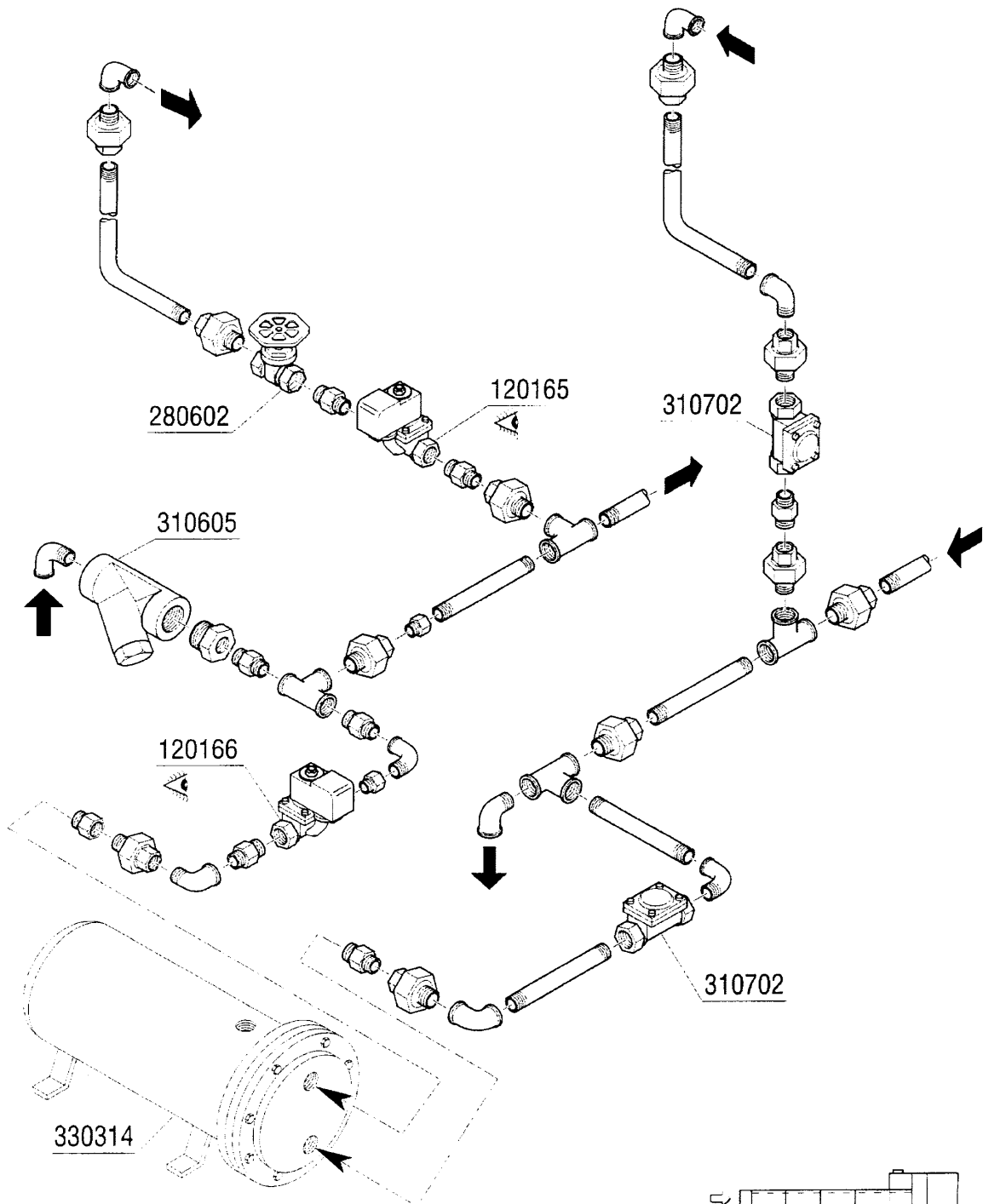

REV. 00
10/1999 - S.A.G.

15 - Steam version

CODE	DESCRIPTION
120165	SOLE.N.VALVE ST.24V50HZ 3/4"
120166	STEAM SOLE.N.VALVE 1" 24V-50
280602	GATE VALVE 3/4" BRASS
310605	STRAINER JU 1 1/2" MOD.45
310702	STEAM TRAP 1/2" MK 25/3
330314	STEAM BOILER 30000 KCAL/H

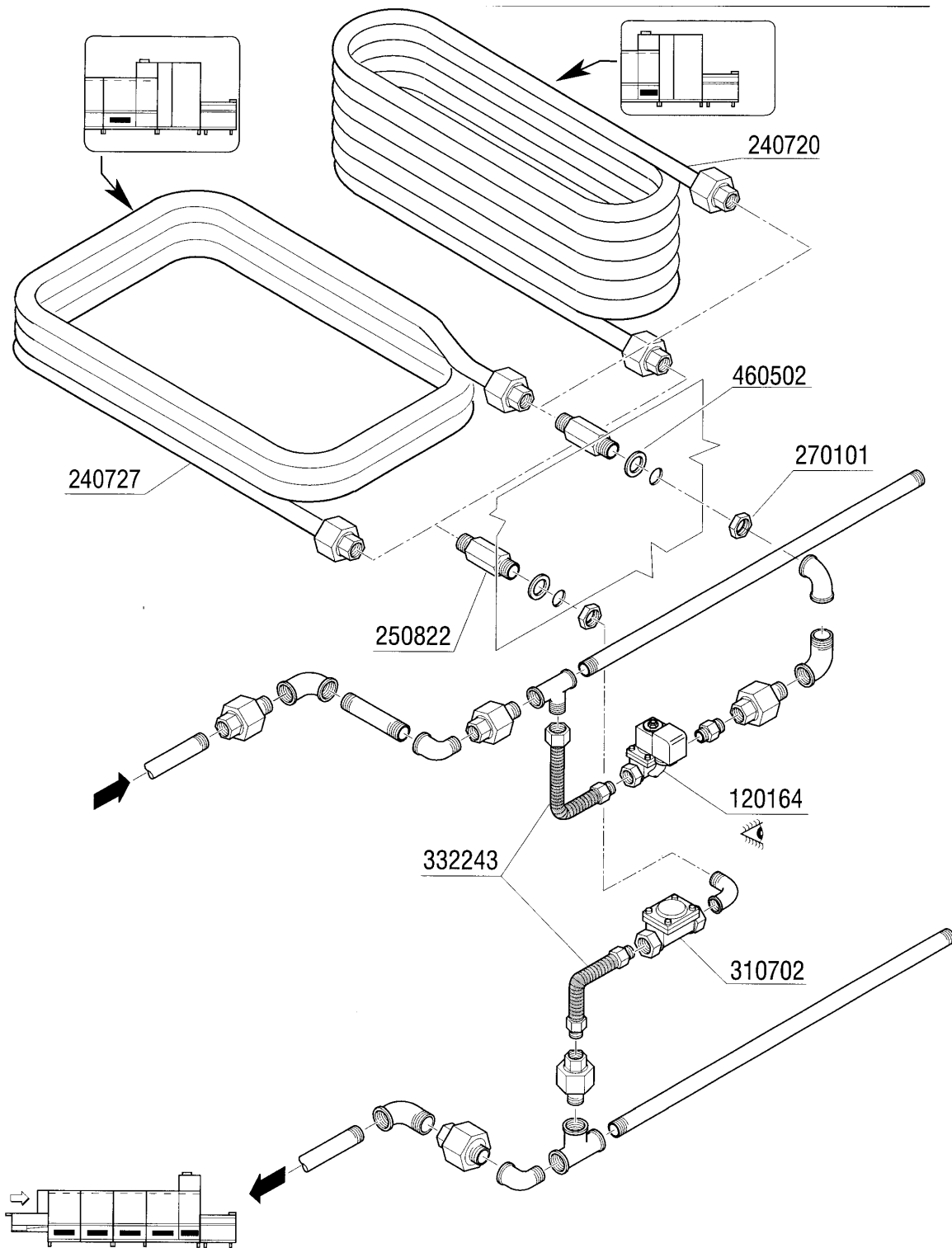

REV. 00
10/1999 - S.A.G.

NOTE: _____

16 - Steam Version

CODE	DESCRIPTION
120164	SOLE.N.VALVE ST.24V50HZ 1/2"
240720	S/S STEAM COIL 12.000KCAL ACR/
240727	STEAM COIL ECORINSE
250822	EXTENSION 1/2"
270101	HEXAGON LOCK NUT 1/2"
310702	STEAM TRAP 1/2" MK 25/3
332243	HOSE 1/2-3/4"-130X220-
460502	GASKET 30X21X2

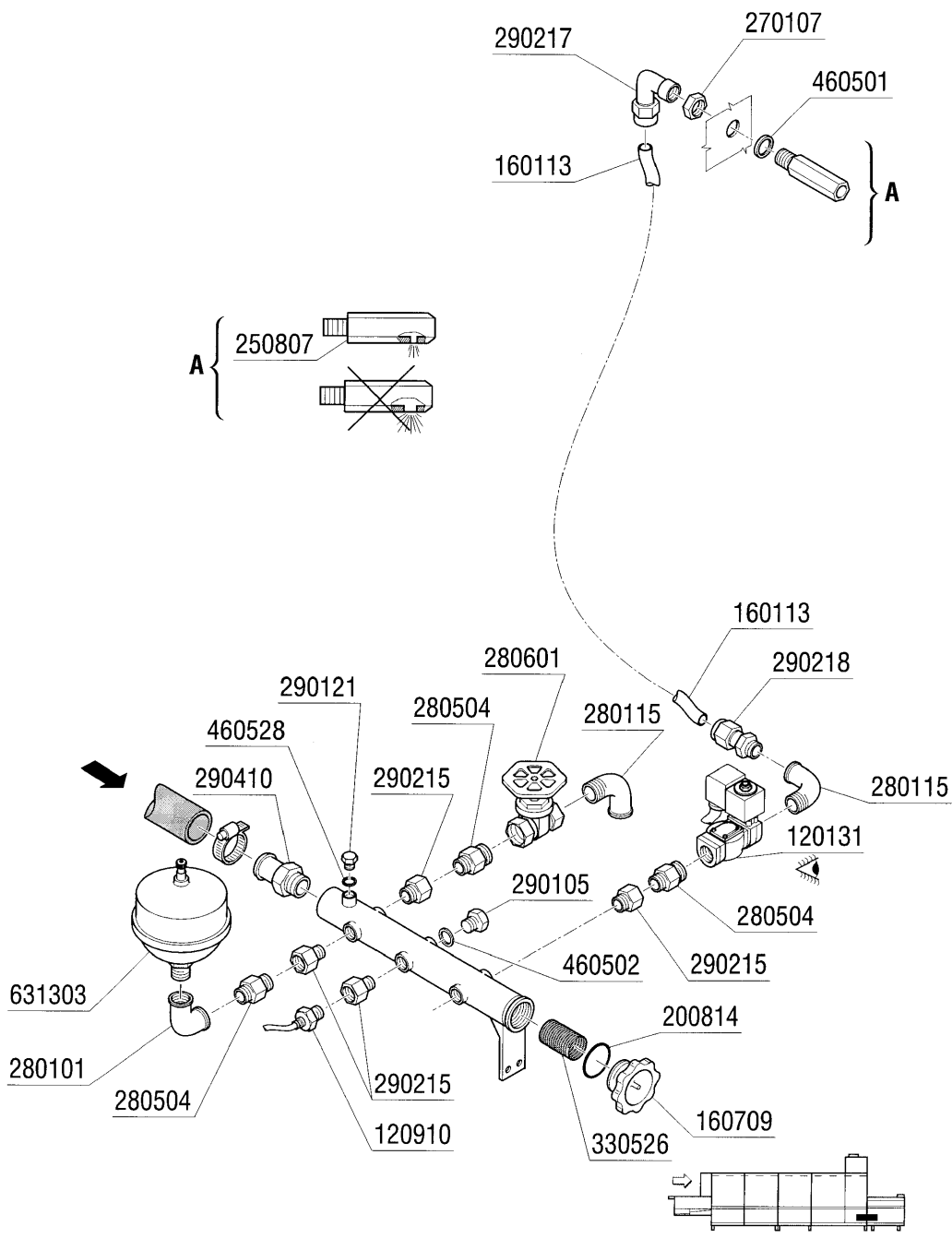

CODE	DESCRIPTION
120131	SOLE. L182Q31-ZB10A 1/2"24V
120910	ELECTRONIC TOUCH PAD CONTROLS
160113	TUBE IN POL. RETIC. 12 EST
160709	KNOB OF MANIFOLD F. SOLEN. VAL
200814	O-RING 34,52X41,58X3,53
250807	ORIESES REDUCT.F.HEAT RECOVERY
270107	BRASS LOCK NUT 3/8" FL803
280101	CRANK F.F 1/2"
280115	ELL 1/2"
280504	MANIFOLD CONN.HOSE
280601	GATE VALVE 1/2" BRASS
290105	BRASS-TE-PLUG 1/2"
290121	BRASS PLUG 1/8"
290215	1/2"BSP M/F UNION BRASS
290217	HOSE CLAMP ELBOW 12X3/8" TYPE
290218	NIPPLE 12X1/2"
290410	NIPPLE 1/2"
330526	FILTERS 22X28 SOLENOID V.MANIF
460501	GASKET 24X17X2
460502	GASKET 30X21X2
460528	GASKET 15X10X2 FOR RINSE NIPPE
631303	HYDRAULIC AIR VESSEL FOR HEAT

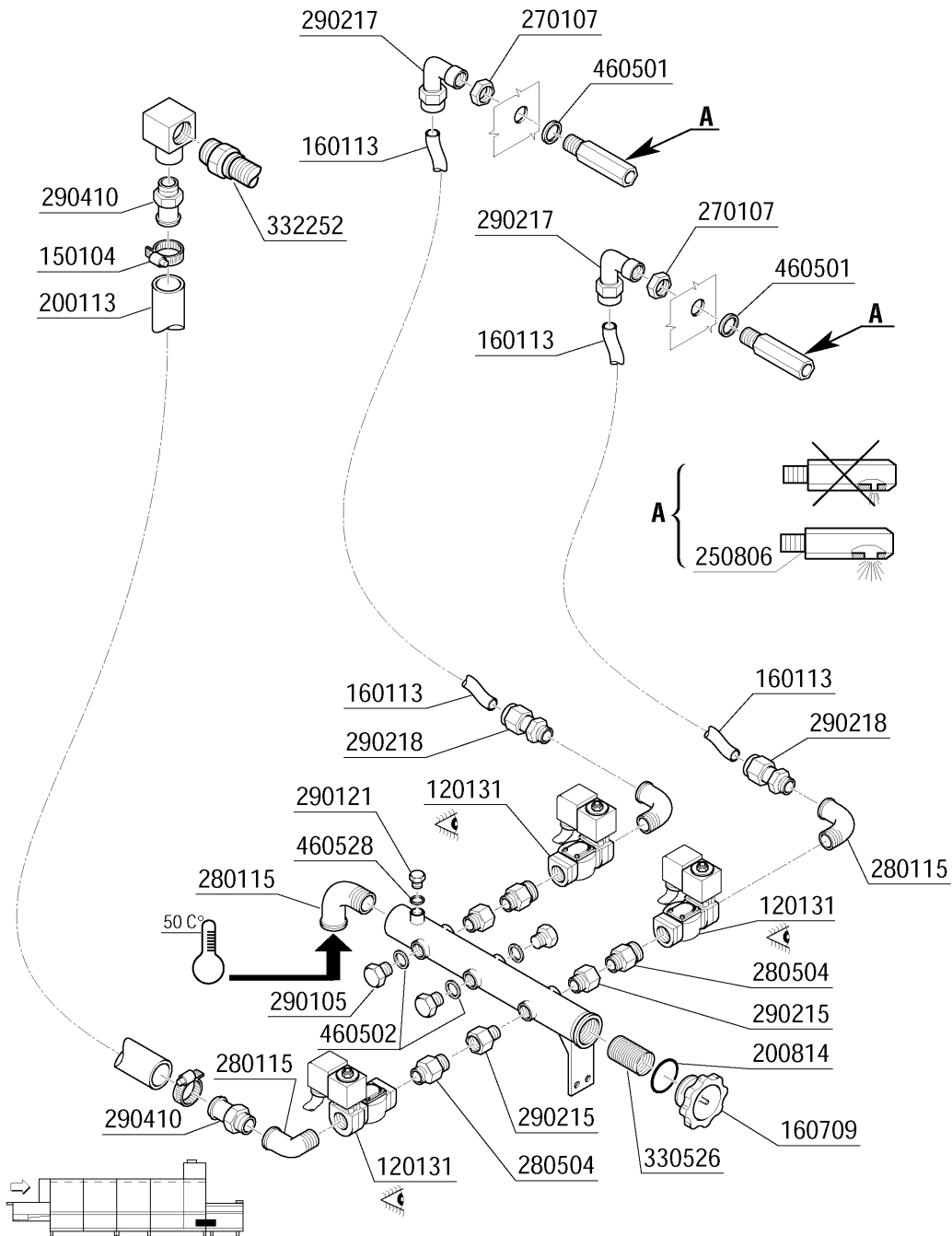

REV. 01
10/1999 - S.A.G.

NOTE: _____

18 - Warm water feed

CODE	DESCRIPTION
120131	SOLEN. L182Q31-ZB10A 1/2"24V
150104	LAMP GREEN 24V RECT.UPQN/
160113	TUBE IN POL. RETIC. 12 EST
160709	KNOB OF MANIFOLD F. SOLEN. VAL
200113	RUBBER HOSE 12 X 22
200814	O-RING 34,52X41,58X3,53
250806	TANK FILL HOSE CLAMP - AC/ACR
270107	BRASS LOCK NUT 3/8" FL803
280115	ELL 1/2"
280504	MANIFOLD CONN.HOSE
290105	BRASS-TE-PLUG 1/2"
290121	BRASS PLUG 1/8"
290215	1/2"BSP M/F UNION BRASS
290217	HOSE CLAMP ELBOW 12X3/8" TYPE
290218	NIPPLE 12X1/2"
290410	NIPPLE 1/2"
330526	FILTERS 22X28 SOLENOID V.MANIF
332252	HOSE 1/2"-220X420-
460501	GASKET 24X17X2
460502	GASKET 30X21X2
460528	GASKET 15X10X2 FOR RINSE NIPPE

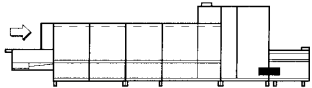
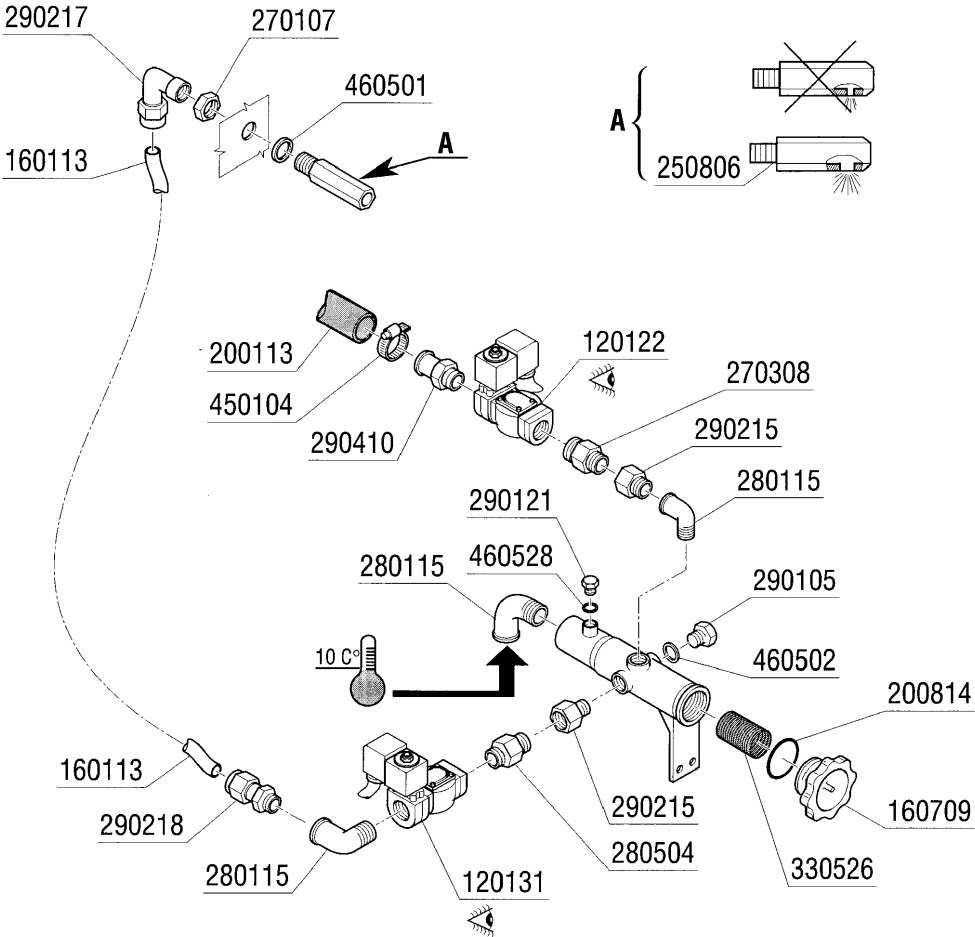

NOTE: _____	REV. 01 10/1999 - S.AG.
-------------	----------------------------

19 - Cold water feed

CODE	DESCRIPTION
120122	SOLENOID VALVE 3/4 24V L180Q17
120131	SOLEN. L182Q31-ZB10A 1/2"24V
160113	TUBE IN POL. RETIC. 12 EST
160709	KNOB OF MANIFOLD F. SOLEN. VAL
200113	RUBBER HOSE 12 X 22
200814	O-RING 34,52X41,58X3,53
250806	TANK FILL HOSE CLAMP - AC/ACR
270107	BRASS LOCK NUT 3/8" FL803
270308	NIPPLES 3/4"
280115	ELL 1/2"
280504	MANIFOLD CONN.HOSE
290105	BRASS-TE-PLUG 1/2"
290121	BRASS PLUG 1/8"
290215	1/2"BSP M/F UNION BRASS
290217	HOSE CLAMP ELBOW 12X3/8" TYPE
290218	NIPPLE 12X1/2"
290410	NIPPLE 1/2"
330526	FILTERS 22X28 SOLENOID V.MANIF
450104	CLAMP FE ZN H=12,5 15-24
460501	GASKET 24X17X2
460502	GASKET 30X21X2
460528	GASKET 15X10X2 FOR RINSE NIPPE

DAMPF-VENTIL - ELETTOVALVOLA VAPORE - ELECTROVANNE VAPEUR
 STEAM SOLENOID VALVE - ELECTROVALVULA VAPOR

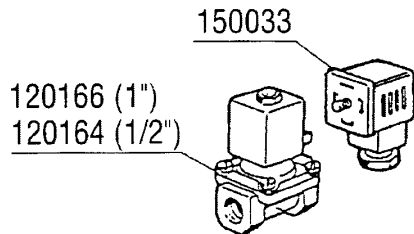

0 ÷ 2 bar

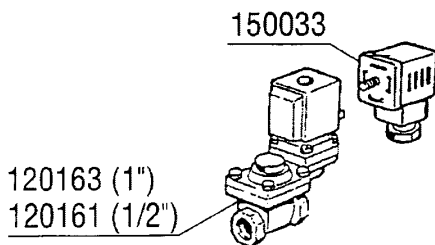
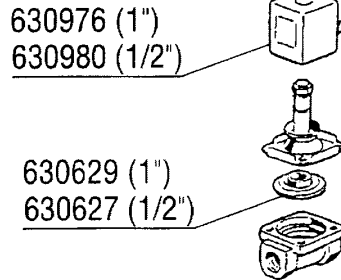

0,5 ÷ 2,5 bar

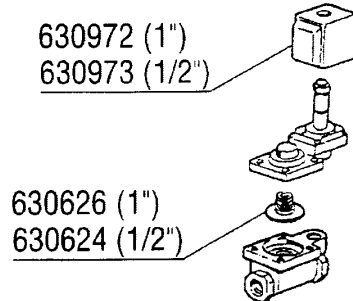

WASSER-VENTIL - ELETTOVALVOLA ACQUA - ELECTROVANNE EAU
 WATER SOLENOID VALVE - ELECTROVALVULA AGUA

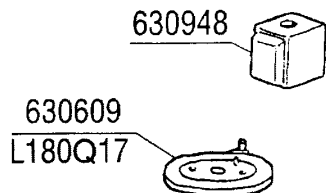
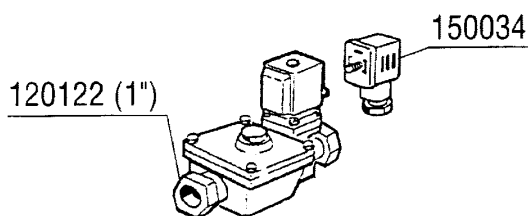
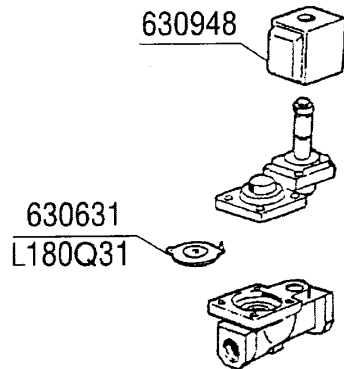
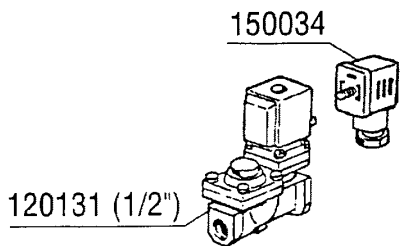

FÜR WÄRMERÜCKGEWINNUNG - PER RECUPERATORE DI CALORE - POUR ECONOMISEUR D'ENERGIE
 FOR HEAT RECOVERY UNIT - PARA RECUPERADOR DE CALOR

REV. 01
 01/2000 - S.AG.

20 - Solenoid Valve

CODE	DESCRIPTION
120122	SOLENOID VALVE 3/4 24V L180Q17
120131	SOLEN. L182Q31-ZB10A 1/2"24V
120161	SOLEN.VAL.ST.L145R1Z734A 1/2
120163	SOLEN.VAL.ST.L145R1Z234A 1"24V
120164	SOLEN.VALVE ST.24V50HZ 1/2"
120166	STEAM SOLEN.VALVE 1" 24V-50
150033	CONNEC.F.SOLEN.VALVE 182.09.N
150034	CONNEC.F.SOLEN.VALVE 122.09.N
630609	DIAPHRAGM L180Q17-3/4
630624	KIT F.SOLEN.VALVE L145 1/2 G26
630626	KIT FOR SOLENOID VALVE 145 1"
630627	KIT F.SOLEN.V. L153D1 1/2"
630629	KIT SOLENOID VALVE 1" STEAM L1
630631	DIAPHRAGM SOL.VALVE
630948	COIL Z610A 24V 50/60-L180V01
630972	COIL Z534A/V.24-L145A-3/4
630973	COIL Z614A/V.24-L145-3/4 A
630976	COIL Z114A/V24/50HZ L153-1"
630980	COIL Z114 24V

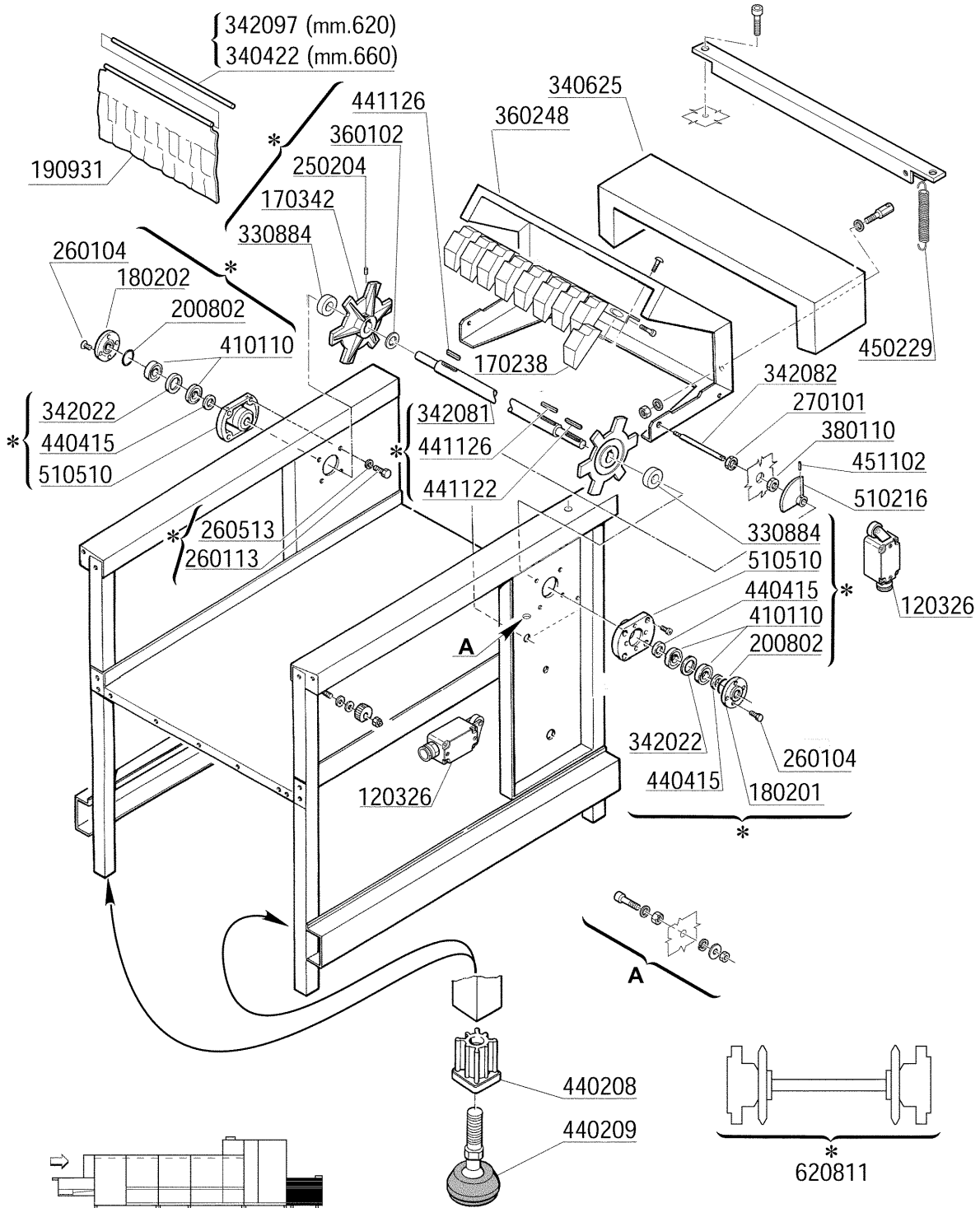

NOTE:

REV. 02
07/2000 - S.A.G.

21 - Exit table

CODE	DESCRIPTION
120326	MICRO SWITCH FD 102
170238	PEG END RUN ARM NE/2
170342	PINION
180201	DRILLED FLANGE 85 /DRIVE
180202	BLIND FLANGE D.85 (DRIVE) N
190931	CURTAIN OUT BTM-NE/2
200802	OR GASKET 3,53X44,05X51,11
250204	GRUB SCREW 6X6
260104	STAINL.ST TE-SCREW A2 6X16 UNI
260113	STAINL.ST.TE SCREW 8X20 A2 UNI
260513	GROWER WASHER D8
270101	HEXAGON LOCK NUT 1/2"
330884	WASHER
340422	SHAFT FOR CURTAIN AC-ACR
340625	EXIT TABLE COVER
342022	WASHER
342081	CONVEYOR SPINDLE
342082	PIN
342097	SHAFT
360102	WASHER
360248	COVER
380110	BRASS BEARING D12 F.ECON.N
410110	BEARINGS 20X42X12 6004
440208	FOOT INSERT
440209	COMPLETE FOOT NE
440415	GASKET MIM 20X30X5 (VITON)
441122	DRIVE SHAFT KEY 6X6X25 UNI 660
441126	DRIVE SHAFT KEY 8X7X40
450229	STAINL.ST SPRING LIMIT SWITCH
451102	RINSE GATE PIN 3X26
510216	N RINSE GATE ECCENTRE
510510	DRIVE AXLE SUPPORT
620811	DRIVE SHAFT NE02

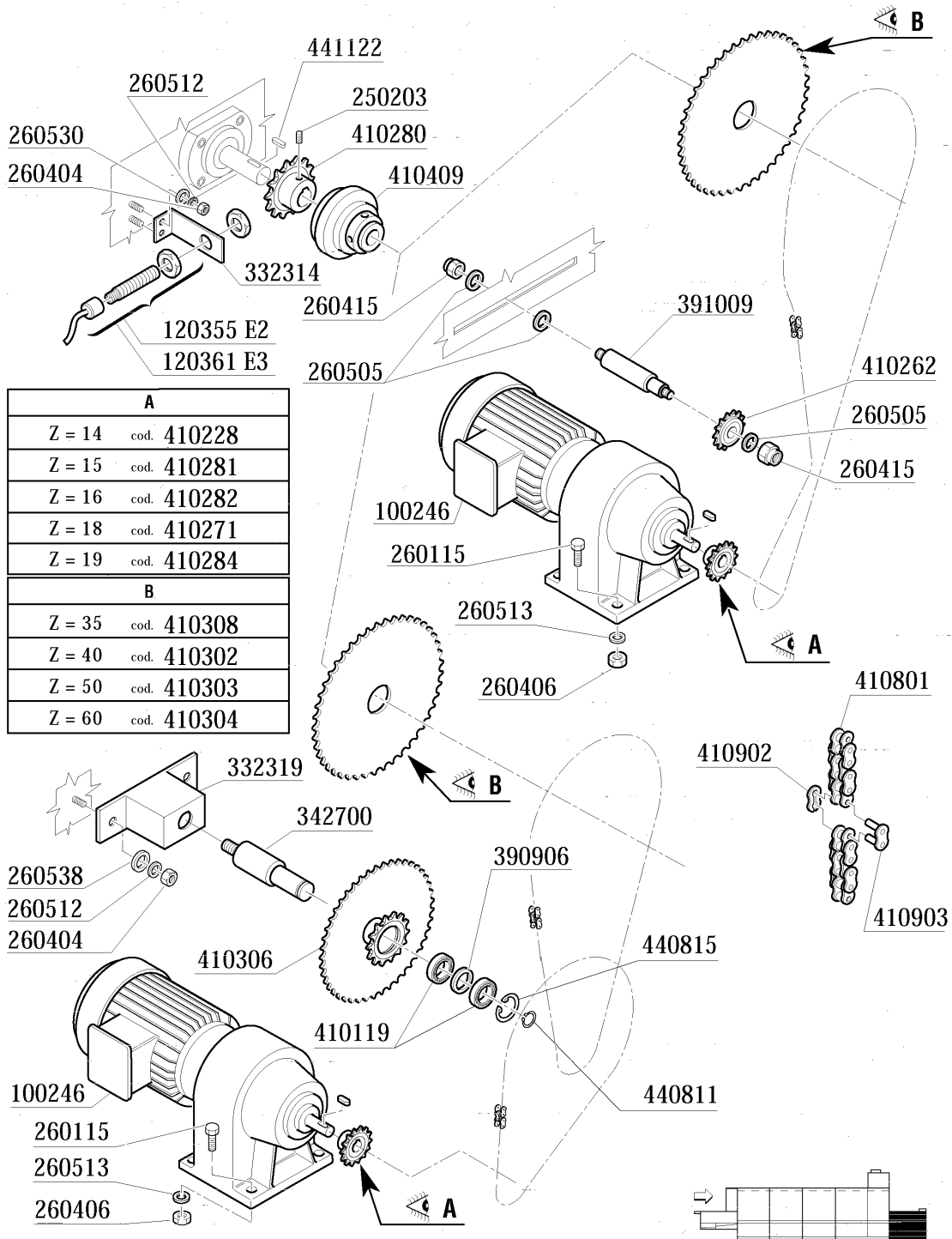

A	
Z = 14	cod. 410228
Z = 15	cod. 410281
Z = 16	cod. 410282
Z = 18	cod. 410271
Z = 19	cod. 410284
B	
Z = 35	cod. 410308
Z = 40	cod. 410302
Z = 50	cod. 410303
Z = 60	cod. 410304

REV. 00
01 - 2005 S.A.G.

NOTE: _____

22 - Drive unit

CODE	DESCRIPTION
100246	DRIVE KW 0,1-0,15 380/3
120355	SENSOR SI12/DC4/PNP NO
120361	SENSOR
250203	GRUB SCREW 8X12
260115	STAIN.ST.TE SCREW 8X20 A2 UNI
260404	STAINLESS STEEL NUTS D6 UNI 55
260406	NUT 8MA
260415	STAINLESS STEEL SELF-LOCKING N
260505	STAINL.STEEL FLAT WASHER D8
260512	ST/ST GROWER WASHER D6
260513	GROWER WASHER D8
260530	STAINL.ST WASHER 7X22X2
260538	WASHER 18X6X1,5 ST/ST
332314	BRACKET
332319	BRACKET
342700	PIN
390906	SPACER
391009	PIN
410119	RADIAL BEARING 32X15X9
410228	TURNED PINION Z14-1/2"-D.19
410262	PINION Z13
410271	PINION Z18 1/2-D.19
410280	PINION Z26
410281	PINION Z15-1/2-D.19
410282	PINION Z16-1/2-D.19
410284	PINION Z19-1/2-D.19
410302	CROWN DISCS 40T 1/2" PITCH
410303	CROWN DISCS 50T 1/2" PITCH
410304	CROWN DISCS 60T 1/2" PITCH
410306	GROUP CROWN-SPROCKET Z14/40
410308	CROWN DISCS 35T 1/2" PITCH
410409	TORQUE LIMITER LC2
410801	DRIVE CHAIN 1/2" N-S
410902	FALSE CHAIN LINK 1/2"
410903	CHAIN JOINT 1/2"
440811	EXTERN.SEALING RING D.15 UNI 7
440815	INTERN.SEAL RING D.32
441122	DRIVE SHAFT KEY 6X6X25 UNI 660

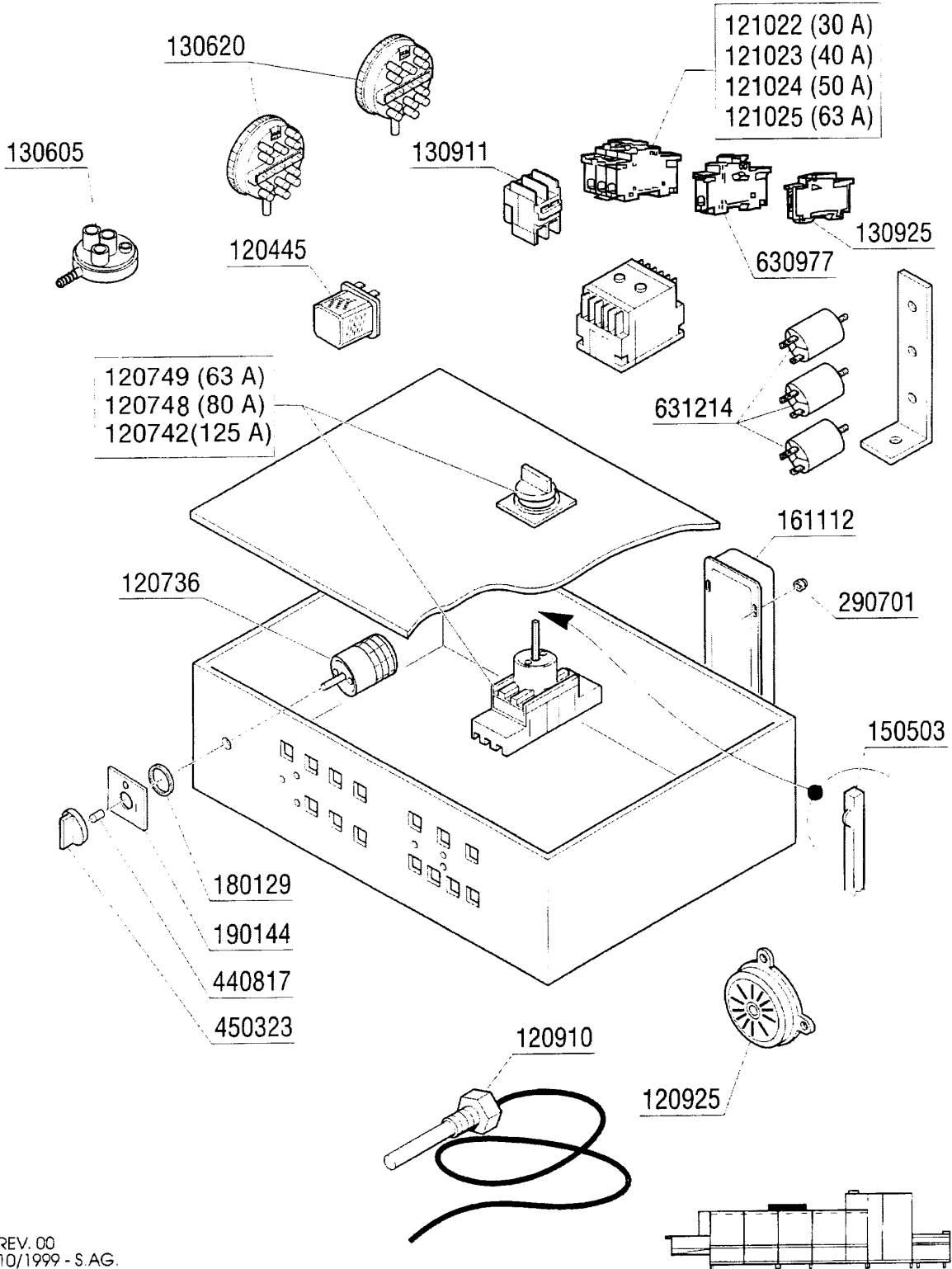

REV. 00
10/1999 - S.AG.

23 - Control Box

CODE	DESCRIPTION
120445	AUXILIARY RELAY S.B2/3 24V
120736	4 POLE MAIN SWITCH 25A 500V
120742	MAIN SWITCH 125A (120745)
120748	MAINSWITCH 80A 4P
120749	MAINSWITCH 63A 4P
120910	ELECTRONIC TOUCH PAD CONTROLS
120925	ACUSTIC SIGNAL
121022	CIRCUIT BREAKER 32A
121023	CIRCUIT BREAKER 40A
121024	CIRCUIT BREAKER 50A
121025	CIRCUIT BREAKER 63A
130605	PRESSURE SWITCH 50-30 1 LEVEL
130620	PRESSURE SWITCH 3 LEVEL 50-30/
130911	CONTACT LA1 D40 A65
130925	CONTACT FOR CIRCUIT BREAKER
150503	EXTENTION FOR MAIN SWITCH
161112	BACK COVER CHANNEL 300 S N
180129	NUT FOR MAIN SWITCH SUPPORT
190144	MAIN SWITCH HOLDER
290701	HEXAGON BLIND NUTS GM H12
440817	SNAP RING LSCB/1853/17/00
450323	KNOB FOR BC-BR-C95-C155
630977	COIL FOR CIRCUIT BREAKER 24V
631214	ANTI-NOISE FILTER 4011135007 3

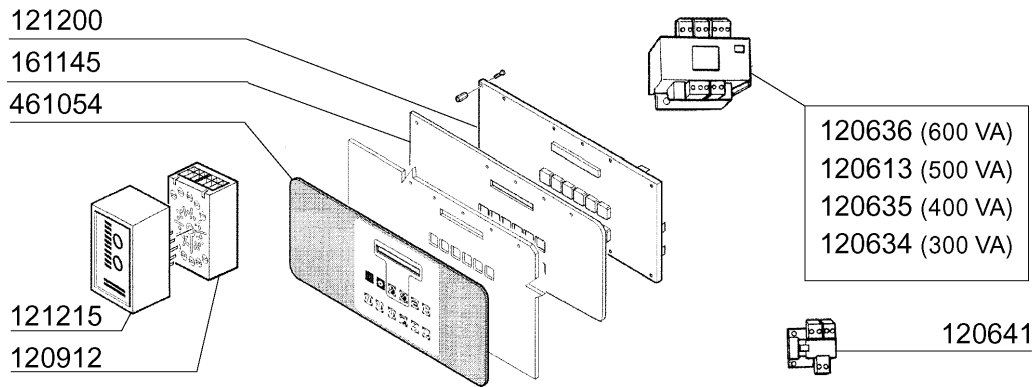

E1

E2

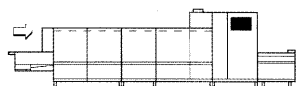
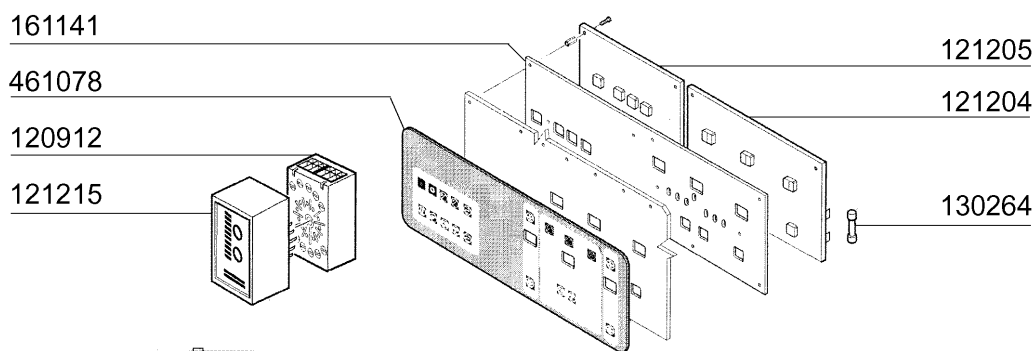
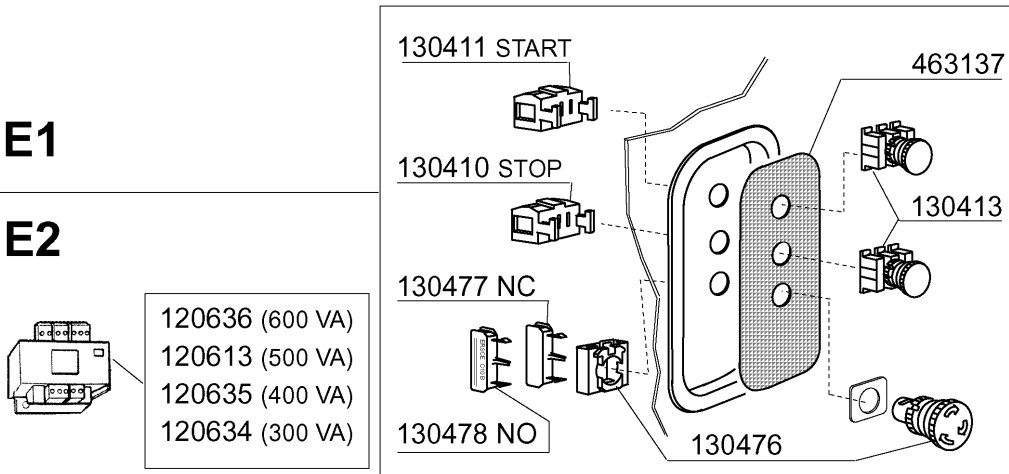

REV.00 05 - 2002 - S. AG.	NOTE _____ _____ _____
------------------------------	------------------------------

24 - Control panel

CODE	DESCRIPTION
120613	TRANSFORMER 500VA 220-240-380-
120634	TRANSFORMER 300VA220-240-380-4
120635	TRANSFORMER 400VA220-240-380-4
120636	TRANSFORMER 600VA220-240-380-4
120641	SAFETY TRANSFORMER 30VA
120912	RELAY SUPPORT
121200	ELECTRONIC PANEL WITH DISPLAY
121204	ELECTRONIC PANEL THERMOREG.7+1
121205	"ELECTRONIC 2" PANEL
121215	ELECTR.TIMER CRTP 24V
130264	FUSE 5X20 1A
130410	STOP CONTACT F40 CN RED
130411	START CONTACT YELLOW
130413	GREEN PUSH BUTTON
130476	ROTATIVE EMERGENCY SWITCH
130477	CONTACT NC
130478	CONTACT N.O.
161141	PROTECTION
161145	PROTECTION ELECT.CARD 1
461054	PLATE "ELECTRONIC 1"
461078	PLATE "ELECTRONIC 2"
463137	SELF ADHESIVE SYMBOL

E 3

120491

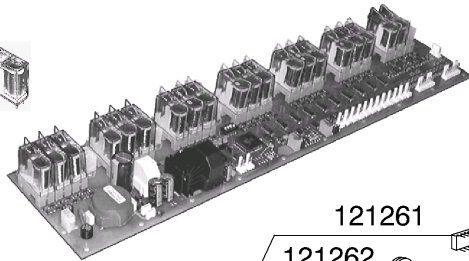

121258

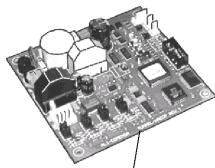

121263 HPS



Kit

121278

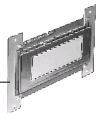

121261

121262

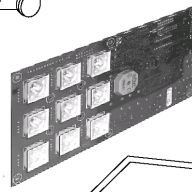

260201

260509

260501

121259



461251

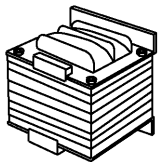

- 120652 (600 VA)
- 120651 (500 VA)
- 120650 (400 VA)
- 120649 (300 VA)
- 120648 (250 VA)

130411 START



130410 STOP



130477 NC



130476

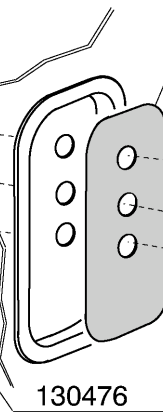

463137



130413



11 - 2002 | S. AG.

25 - Control panel

CODE	DESCRIPTION
120491	RELAIS 10A 9V
120648	TRANSFORMER 250VA225-240-380-4
120649	TRANSFORMER 300VA225-240-380-4
120650	TRANSFORMER 400VA225-240-380-4
120651	TRANSFORMER 500VA225-240-380-4
120652	TRANSFORMER 600VA225/415-24/24
121258	MAIN PCB E3
121259	KEYBOARD PCB
121261	WATCH
121262	LITHIUM BATTERY 3V.CR2450N
121263	HPS BOARD
121278	DISPLAY LCD 4X16
130410	STOP CONTACT F40 CN RED
130411	START CONTACT YELLOW
130413	GREEN PUSH BUTTON
130476	ROTATIVE EMERGENCY SWITCH
130477	CONTACT NC
260201	SCREW TCP 3X10
260501	STAINL.STEEL FLAT WASHER D3 UN
260509	GROWER WASHER D.3
461251	PLATE E3 (NEUTRAL)
463137	SELF ADHESIVE SYMBOL

DC

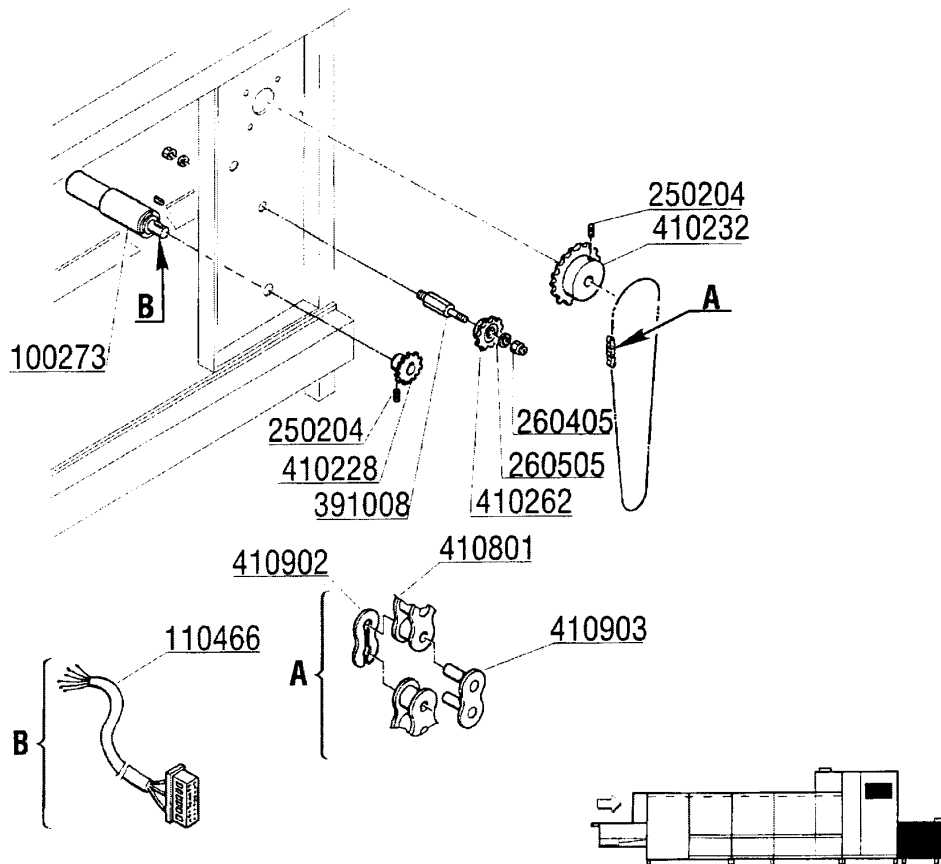
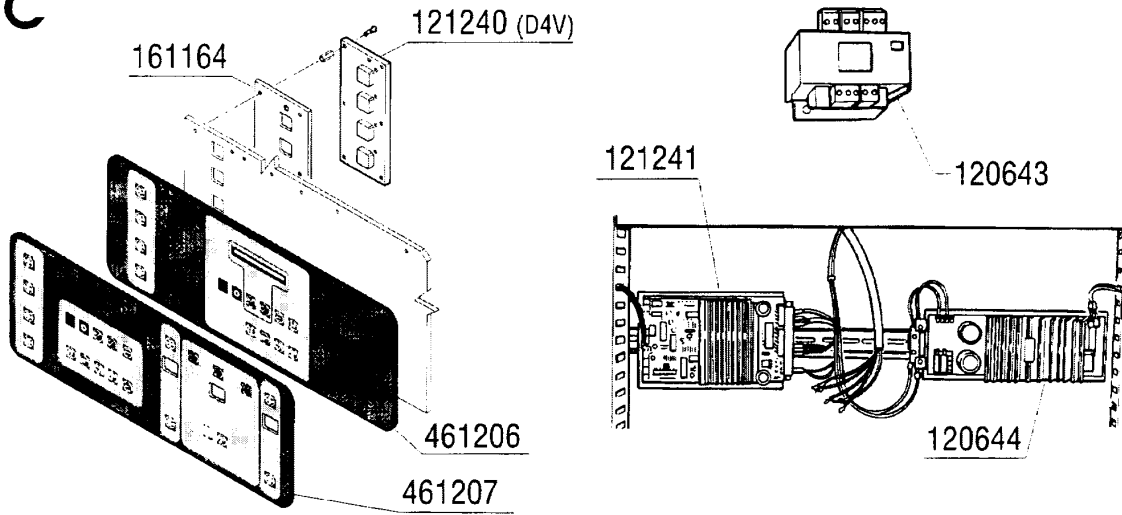

REV. 00
10/1999 - S.A.G.

26 - 4 speedy components

CODE	DESCRIPTION
100273	DC DRIVE MOTOR
110466	WIRING FOR DRIVE MOTOR
120643	TRANSFORMER 700VA
120644	TRANSFORMER 24V 10A
121240	SPEED SELECTION ELECTRONIC PAN
121241	ELECTRONIC PANEL FOR MOTOR
161164	PROTECT. SPEED SWITCHBOARD
250204	GRUB SCREW 6X6
260405	NUT D.8
260505	STAINL.STEEL FLAT WASHER D8
391008	PIN
410228	TURNED PINION Z14-1/2"-D.19
410232	TURNED PINION Z25-1/2"-D.20
410262	PINION Z13
410801	DRIVE CHAIN 1/2" N-S
410902	FALSE CHAIN LINK 1/2"
410903	CHAIN JOINT 1/2"
461206	CONTROL PANEL
461207	FRONT PANEL

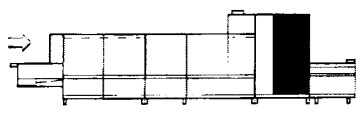
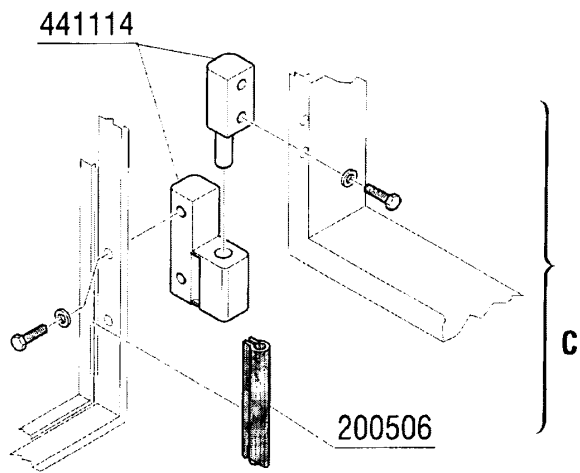
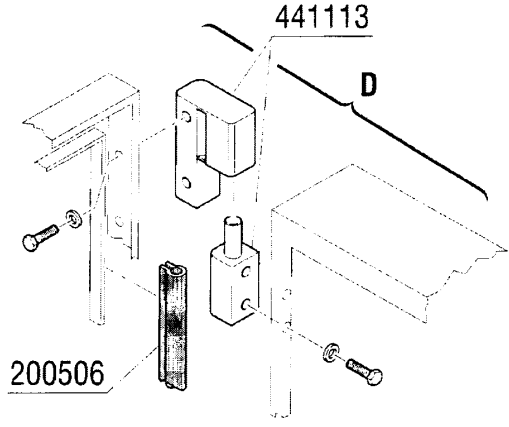
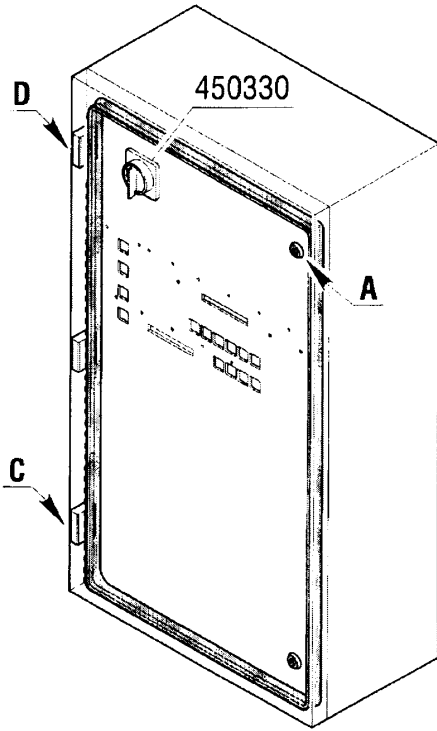
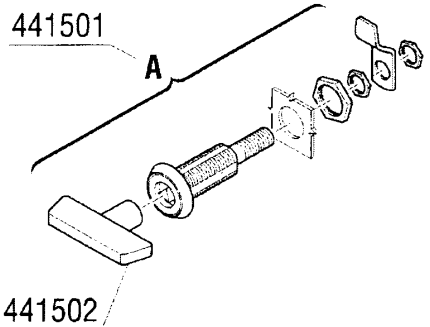

REV. 00
10/1999 - S.A.G.

27 - Mounted control panel

CODE	DESCRIPTION
200506	GASKET GUI SNAP UNIVERS.861
441113	DOOR HINGE SOUTHCO
441114	DOOR HINGE SOUTHCO
441501	LOCK
441502	KEY FOR CONTROL PANEL
450330	KNOB FOR MAIN SWITCH

451002
340405
330113

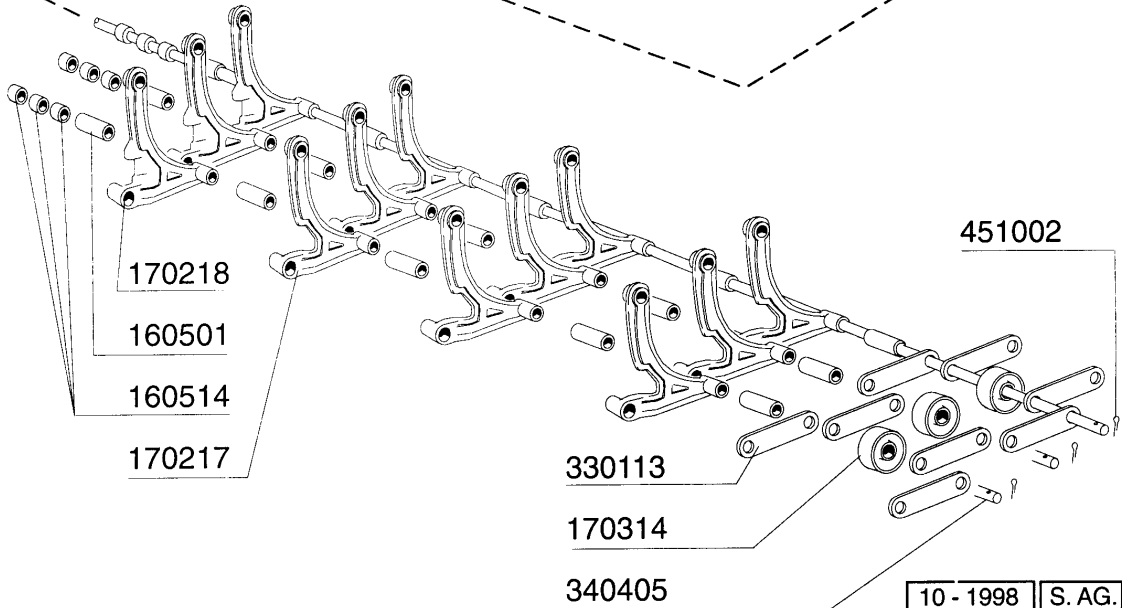
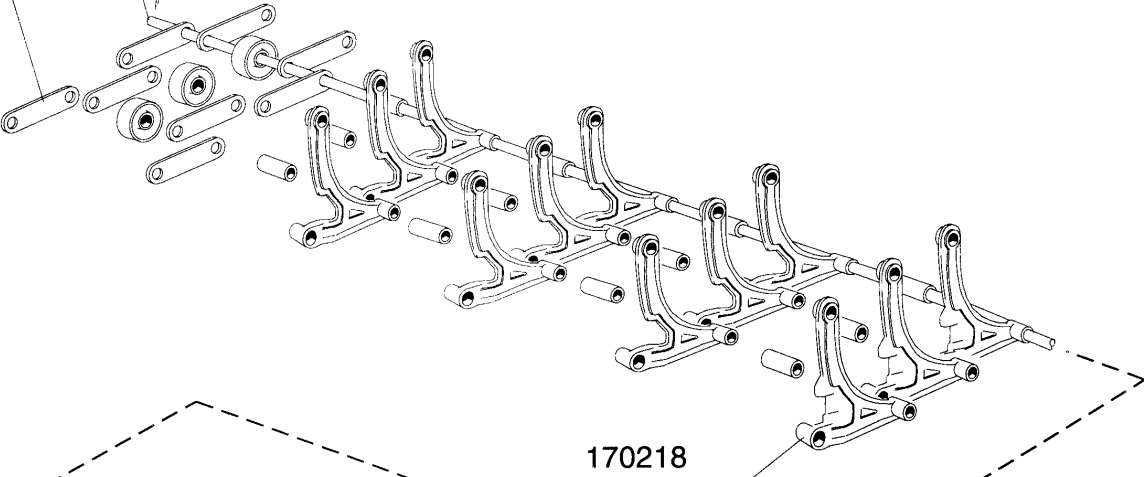
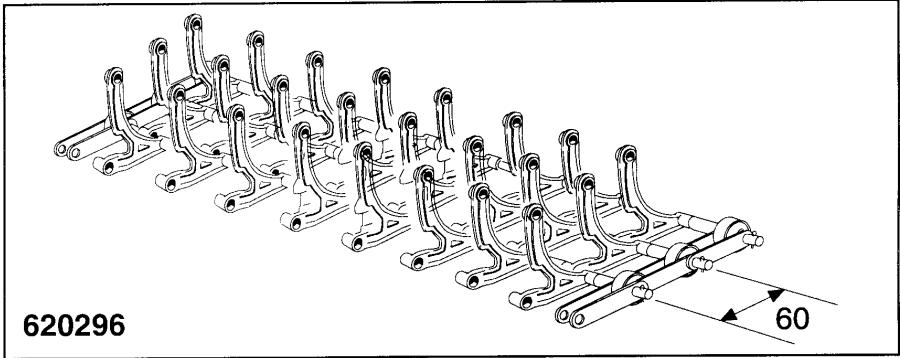

28 - Conveyor 600mm

CODE	DESCRIPTION
160501	SPACER FLIGHT D.9X25 CONVEYOR
160514	SPACER 7,9 108378 MOP
170217	FINGER FOR BELT 60MM
170218	CENTRAL FINGER 60MM CONVEYOR B
170314	GRAY BELTWHEEL N
330113	LINKS
340405	SHAFT FOR BELTN D.8X611
451002	COTTER PIN STAINL.ST. D2X12
620296	KIT BELT CONVEYOR NE

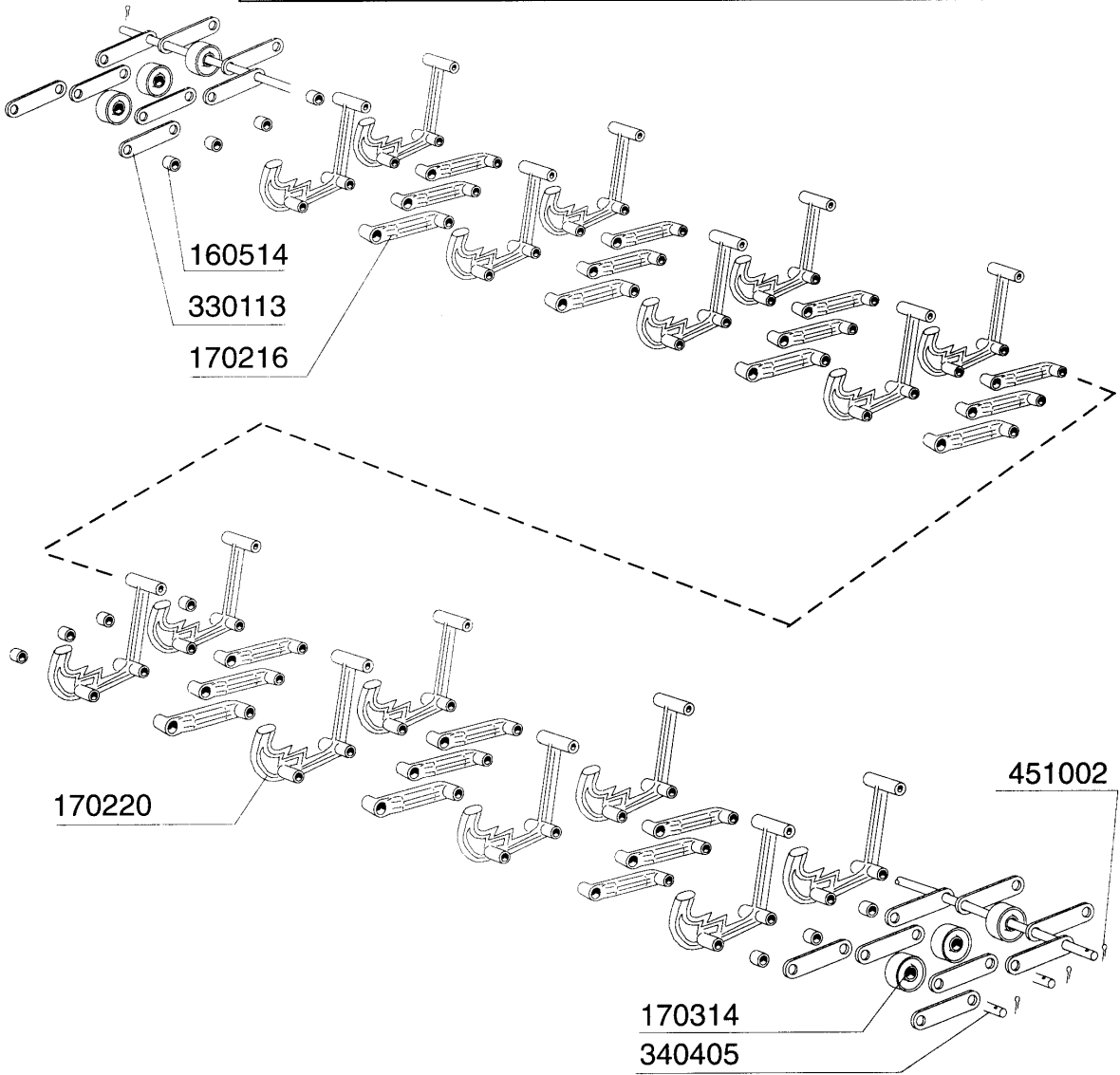
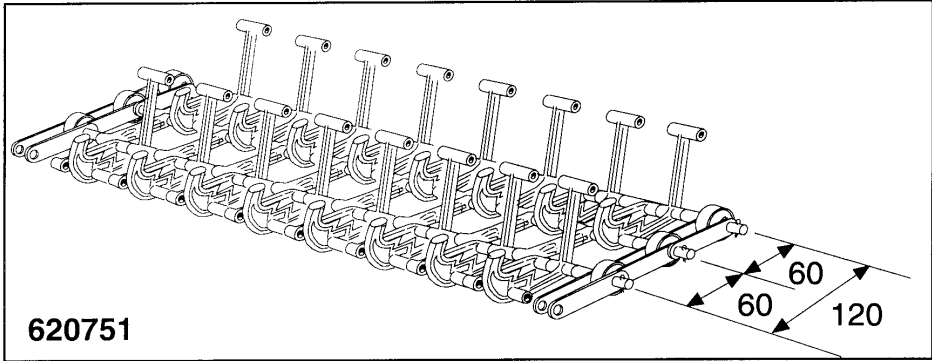

29 - Conveyor 600mm

CODE	DESCRIPTION
160514	SPACER 7,9 108378 MOP
170216	SPACER FOR BELT 60MM
170220	FINGER FOR TEMP-RITE BELT
170314	GRAY BELTWHEEL N
330113	LINKS
340405	SHAFT FOR BELTN D.8X611
451002	COTTER PIN STAINL.ST. D2X12
620751	KIT TEMPRITE BELT

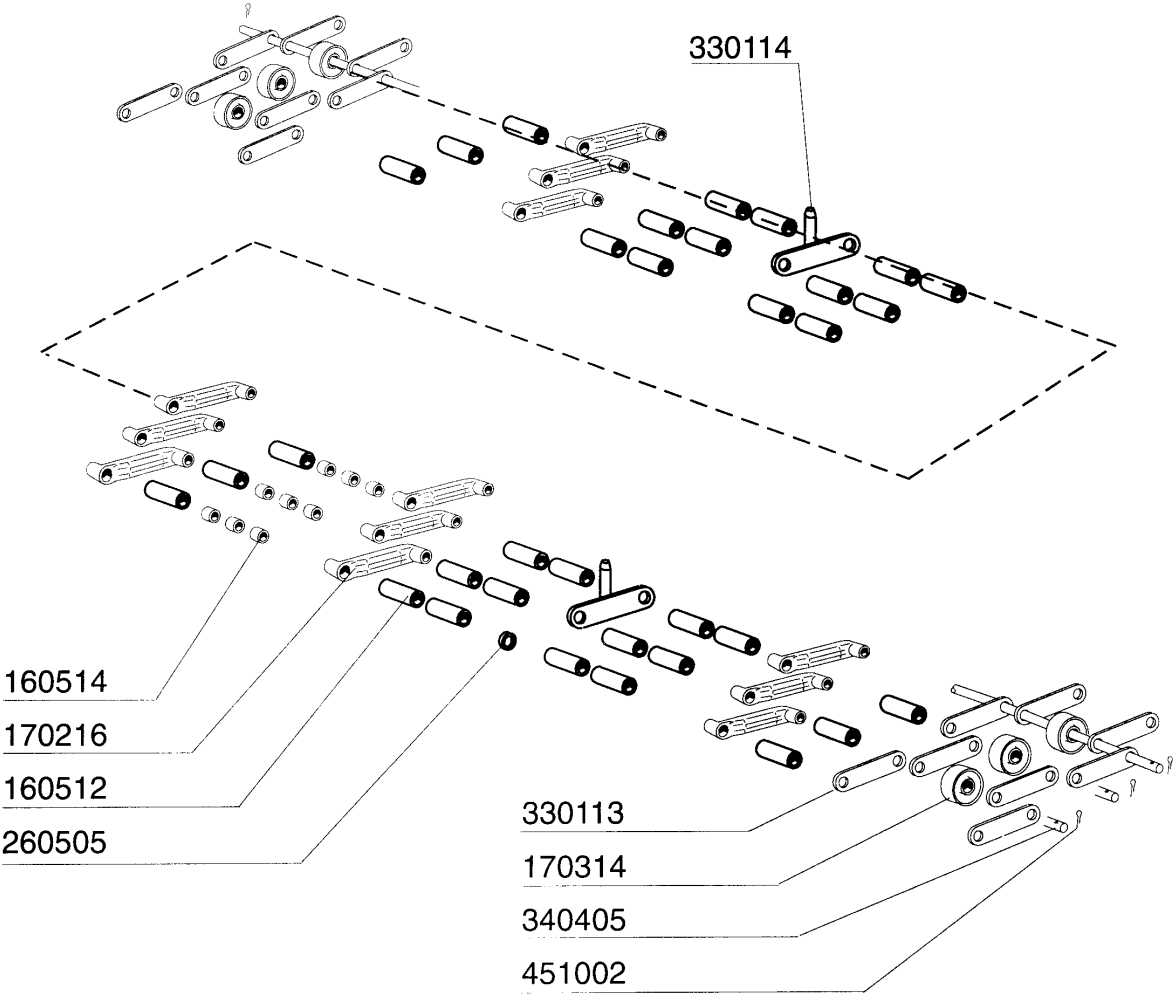
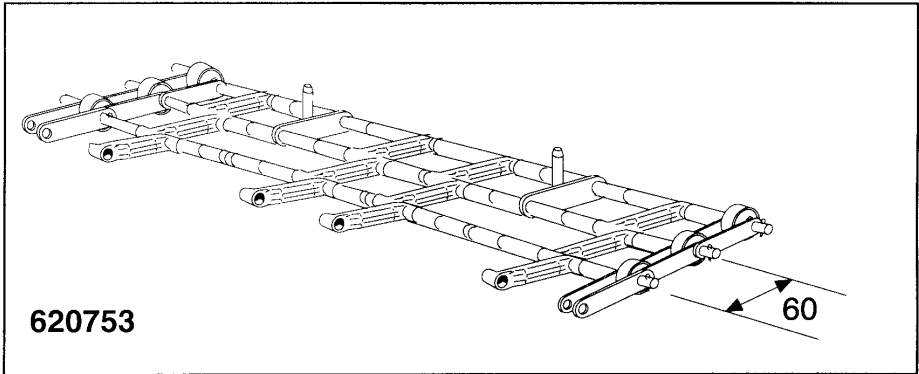

30 - Conveyor 600mm

CODE	DESCRIPTION
160512	SPACER 35,5
160514	SPACER 7,9 108378 MOP
170216	SPACER FOR BELT 60MM
170314	GRAY BELTWHEEL N
260505	STAINL.STEEL FLAT WASHER D8
330113	LINKS
330114	S/S FINGER FOR N P60 FLAT CONV
340405	SHAFT FOR BELTN D.8X611
451002	COTTER PIN STAINL.ST. D2X12
620753	KIT BELT CONVEYOR NE

VORSPÜLUNGSPUMPE - POMPA PRELAVAGGIO - PREWASH PUMP - POMPE PRELAVAGE - BOMBA PRELAVADO
1,5 KW (1204)

INOX
631669 (50 Hz) ø 90

630223
630501
630114
630411
630306
630216

100762 220-240-380-415 V
50 Hz-3

WASCHPUMPE - POMPA LAVAGGIO - WASH PUMP - POMPE LAVAGE - BOMBA LAVADO
2,7 KW (2275)

INOX
631678 (60 Hz) ø117
631672 (50 Hz) ø134,5

630232
630516
630122
630418
630315

100398 220/380 V 50 Hz-3
100633 240/415 V 50 Hz-3
100638 220/380 V 60 Hz-3

DOPPELNACHSPÜLUNGSPUMPE - POMPA DOPPIO RISCIAQUO - DOUBLERINSE PUMP
POMPE DOUBLE RINÇAGE - BOMBA DOBLE ACLARADO
0,15 KW (4226)

INOX
ø 60 (60 Hz)
631675 ø 72 (50 Hz)

630235
630511
630125
630416

100647 220/240/380/415 V 50 Hz-3
100669 240/240/380/415 V 60 Hz-3

ELEKTRISCHE TEILE FÜR PUMPEN - COMPONENTI ELETTRICI POMPE - COMPOSANTS ELECTRIQUES POMPES -
ELECTRICAL PARTS FOR PUMPS - PIEZOS ELECTRICOS PARA BOMBAS

220/240 V					380/415 V						
PUMPE POMPA POMPE PUMP BOMBA		SCHALTSCHÜTZ TELERUTTORE CONTACTEUR CONTACTOR			MAGNETISCHER SCHLTER FÜR MOTORE MAGNETOTERMICI PER MOTORI MAGNETO-THERMIQUE TERMO-MAGNETIC SWICH FOR MOTOR MAGNETO-TÉRMICO PARA MOTORES			SCHALTSCHÜTZ TELERUTTORE CONTACTEUR CONTACTOR		MAGNETISCHER SCHLTER FÜR MOTORE MAGNETOTERMICI PER MOTORI MAGNETO-THERMIQUE TERMO-MAGNETIC SWICH FOR MOTOR MAGNETO-TÉRMICO PARA MOTORES	
HP	Kw	A	cod.	A	cod.	A	cod.	A	cod.		
0,2	0,15	9	120468	1+ 1,6	121030	9	120468	0,4 ÷ 0,63	121028		
2	1,5	9	120468	5,5 ÷ 8	121034	9	120468	2,5 ÷ 4	121032		
3,7	2,7	17	120470	10 ÷ 13	121035	9	120468	4 ÷ 6,3	121033		

REV. 00
11/1998 - S.AG.

NOTE: _____

CODE	DESCRIPTION
100398	PUMP HP 3,7 220/380/50-2275
100633	PUMP HP 0,37 (100398)
100638	PUMP HP 3,7 220/380/3-60 1275
100647	PUMP HP 0,20 220/240/3 4226
100669	PUMP HP 0,12 220/380 60HZ C16
100762	PUMP HP2 - 1204 (100693)
120468	CONTACTOR ABB 9A 24V 50/60HZ
120470	CONTACTOR ABB 16A 24V 50/60HZ
121028	CIRCUIT BREAKER 0,4-0,63A
121030	CIRCUIT BREAKER 1,0-1,6A
121032	CIRCUIT BREAKER 2,5-4,0A
121033	CIRCUIT BREAKER 4,0-6,3A
121034	CIRCUIT BREAKER 6,3-9A
121035	CIRCUIT BREAKER 9-12,5A
630114	VOLUTE FI HP2-2,7-3-3,2
630122	VOLUTE HP3,7 /2275
630125	VOLUTE 0,12/0,3(2212-29)
630216	FAN HOUSING FIR HP 2-3
630223	BACK PLATE PUMP HP2-3-3,2
630232	BACKPLATE HP3,7/FIR 2275
630235	PUMP COVER 0,12/0,3 2212-19
630306	PUMP FAN IMPELLOR FI HP.2-3
630315	COOLING FAN F.PUMP 2275 HP 3,7
630411	O-RING PUMP FI HP 2-2,7
630416	OR FOR VOLUTE 0,12/0,3
630418	PUMP GASKET 3,7HP 2275
630501	SEAL FOR PUMP HP 2-3-3,2
630511	PUMP SEAL HP 0,10 82
630516	PUMP SEAL HP 3,7
631669	ST/ST IMPELLER 1,5HP 1241
631672	IMPELLER 50HZ FOR PUMP 100398
631675	ST/ST PUMP IMPELLER 0,2HP 2226
631678	IMPELLER 60HZ FOR PUMP 100398

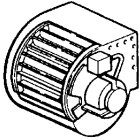
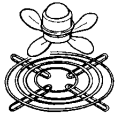
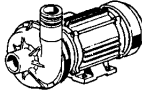
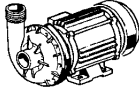
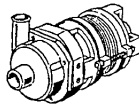
	220/240 V 3 ~				380/415 V 3 ~				
	KW	SCHALTSCHÜTZ TELERUTTORE CONTACTEUR CONTACTOR	A	MAGNETISCHER SCHALTER FÜR MOTORE MAGNETOTERMICI PER MOTORI MAGNETO-THERMIQUE TERMO-MAGNETIC SWICH FOR MOTOR MAGNETO-TÉRMICO PARA MOTORES	A	SCHALTSCHÜTZ TELERUTTORE CONTACTEUR CONTACTOR	A	MAGNETISCHER SCHALTER FÜR MOTORE MAGNETOTERMICI PER MOTORI MAGNETO-THERMIQUE TERMO-MAGNETIC SWICH FOR MOTOR MAGNETO-TÉRMICO PARA MOTORES	A
	1,5	120468	9	121033	4 + 6,3	120468	9	121032	2,5+4
	1,2	120468	9	121030	1+1,6	120468	9	121027	0,25+0,4
	1,5	120468	9	121033	4+6,3	120468	9	121032	2,5+4
	2,7	120470	16	121035	9+12,5	120468	9	121033	4+6,3
	0,15	120468	9	121030	1+1,6	120468	9	121028	0,4+0,63

NOTE: _____

REV. 00
11/1998 - S.AG.

CODE	DESCRIPTION
120468	CONTACTOR ABB 9A 24V 50/60HZ
120470	CONTACTOR ABB 16A 24V 50/60HZ
121027	CIRCUIT BREAKER 0,25-0,4A
121028	CIRCUIT BREAKER 0,4-0,63A
121030	CIRCUIT BREAKER 1,0-1,6A
121032	CIRCUIT BREAKER 2,5-4,0A
121033	CIRCUIT BREAKER 4,0-6,3A
121035	CIRCUIT BREAKER 9-12,5A

33 - Electrical parts for heatings elements

		220/240 V				380/415 V				
KW	A	TERMO-MAGNETISCHER SCHALTER F. HEIZKÖRPER MAGNETOTERMICO RESISTENZA MAGNETO-THERMIQUE RESISTANCE TERMO-MAGNETIC SWITCH FOR HEATER MAGNETO-TERMICO RESISTENCIA	A		SCHALTSCHÜTZ TELERUTTORE CONTACTEUR CONTACTOR	A	TERMO-MAGNETISCHER SCHALTER F. HEIZKÖRPER MAGNETOTERMICO RESISTENZA MAGNETO-THERMIQUE RESISTANCE TERMO-MAGNETIC SWITCH FOR HEATER MAGNETO-TERMICO RESISTENCIA	A		SCHALTSCHÜTZ TELERUTTORE CONTACTEUR CONTACTOR
6,00	20	121020	25	12	120469	16	121019	22	9	120468
9,00	32	121022	40	26	120471	20	121020	25	12	120469
12	40	121023	40	26	120471	20	121020	25	12	120469
14	40	121023	55	30	120472	32	121022	40	26	120471
23	80	121026	85	50	120474	50	121024	60	40	120473
24	80	121026	95	63	120475	50	121024	60	40	120473
27	80	121026	95	63	120475	50	121024	60	40	120473

Cod. 630977	Cod. 130925
AUSLÖSESPÜLE V. 24 FÜR BOILER BOBINA DI SGANCIO V. 24 PER BOILER BOBINE DÉCROCHAGE V.24 POUR SURCHAUFFEUR DISCONNECTING COIL V.24 FOR BOILER BOBINA DESEMBRAGUE V. 24 POR BOILER	KONTAKT FÜR AUSLÖSESPÜLE CONTACTO PER BOBINA DI SGANCIO CONTACT BOBINE DÉCROCHAGE CONTACT FOR DISCONNECTING COIL CONTACTO POR BOILER DE DESEMBRAGUE

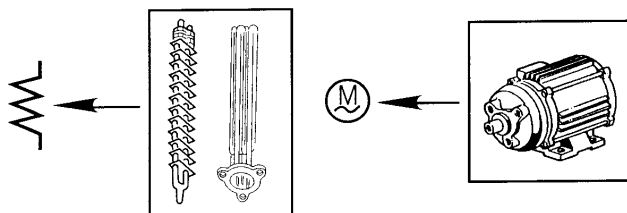

REV. 00 11/1998 - S.AG.	NOTE: _____ _____
----------------------------	----------------------

33 - Electrical parts for heatings elements

CODE	DESCRIPTION
120468	CONTACTOR ABB 9A 24V 50/60HZ
120469	CONTACTOR ABB 12A 24V 50/60HZ
120471	CONTACTOR ABB 26A 24V 50/60HZ
120472	CONTACTOR ABB 24V 50/60HZ
120473	CONTACTOR ABB 24V 50/60HZ
120474	CONTACTOR ABB 50A 24V 50/60HZ
120475	CONTACTOR ABB 63A 24V 50/60HZ
121019	MAGNETOT.SWITCH S253C16
121020	CIRCUIT BREAKER 20A
121022	CIRCUIT BREAKER 32A
121023	CIRCUIT BREAKER 40A
121024	CIRCUIT BREAKER 50A
121026	MAGN.SWITCH 80A
130925	CONTACT FOR CIRCUIT BREAKER
630977	COIL FOR CIRCUIT BREAKER 24V

MODELLO MODELE MODEL MODELL MODELO	PRELAVAGGIO 900 PRELAVAGE 900 PREWASH 900 WORWASCHZONE 900 PRELAVADO 900	1° LAVAGGIO 1 ^{EME} LAVAGE 1 RD WASH 1. WASCHZONE 1. LAVADO	2° LAVAGGIO 2 ^{EME} LAVAGE 2 RD WASH 2. WASCHZONE 2. LAVADO	3° LAVAGGIO 3 ^{EME} LAVAGE 3 RD WASH 3. WASCHZONE 3. LAVADO	4° LAVAGGIO 4 ^{EME} LAVAGE 4 RD WASH 4. WASCHZONE 4. LAVADO	DOPPIO RISCACQUO DOUBLE RINCAGE DOUBLE RINSE DOPPELNACHSPÜLUNG DOBLE ACLARADO	RISCACQUO RINCAGE RINSE NACHSPÜLUNG ACLARADO
NE 3002		8 KW + 6 KW				5 KW	8 KW + 8 KW
NE 4002		8 KW + 6 KW				5 KW	9 KW + 9 KW
NE 5002	9 KW	8 KW + 6 KW				6 KW	6 KW + 6 KW + 9 KW
NE 5502		6 KW + 6 KW	8 KW + 6 KW			6 KW	6 KW + 8 KW + 9 KW
NE 7002	9 KW	6 KW + 6 KW	8 KW + 6 KW			6 KW	8 KW + 8 KW + 8 KW
NE 7502		6 KW + 6 KW	6 KW + 6 KW	8 KW + 6 KW		6 KW	9 KW + 9 KW + 9 KW
NE 9002	9 KW	6 KW + 6 KW	6 KW + 6 KW	8 KW + 6 KW		6 KW	9 KW + 9 KW + 10 KW
NE 9502		6 KW + 6 KW	6 KW + 6 KW	8 KW + 6 KW	8 KW + 6 KW	6 KW	10 KW + 10 KW + 10 KW

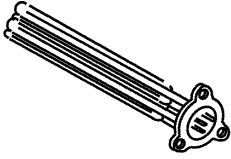
		380 / 415 V
	6 KW	110349
	8 KW	110343
	9 KW	110362
	10 KW	110388

09 - 2000 | S. AG.

34 - Heating Elements

CODE	DESCRIPTION
110343	HEAT.ELEM. 8000W 220/380V
110349	HEAT.ELEMENT 6000W 230/400V
110362	HEAT.ELEMENT 9000W 220/380V
110388	HEAT.ELEMENT 10000W 230/400V

35 - Spring for counterbalancing doors

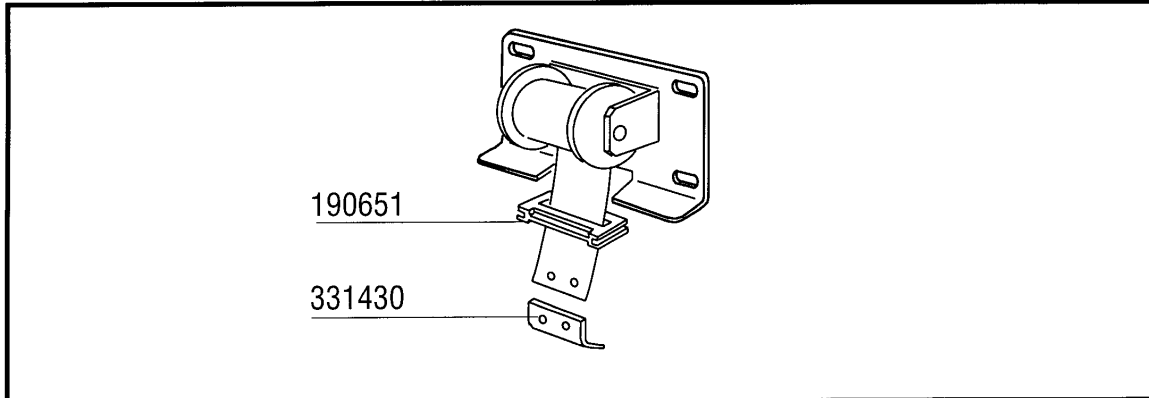

Cod.		391309	391318	391332
		Kg 4	Kg 4,5	Kg 5,5
Türtyp Tipo porta Type porte Door type Modelo puerta	Kg			
600	15			N. 2 = 11 Kg
900	21,5	N. 4 = 16 Kg		

REV. 01
11/1998 - S. AG.

NOTE: _____

35 - Spring for counterbalancing doors

CODE	DESCRIPTION
190651	BUSH
331430	BRACKET FOR DOOR SPRING
391309	DOOR SPRING 4KG - 40MM
391318	DOOR SPRING 4,5KG - 40MM
391332	DOOR SPRING 5,5 KG - 40MM

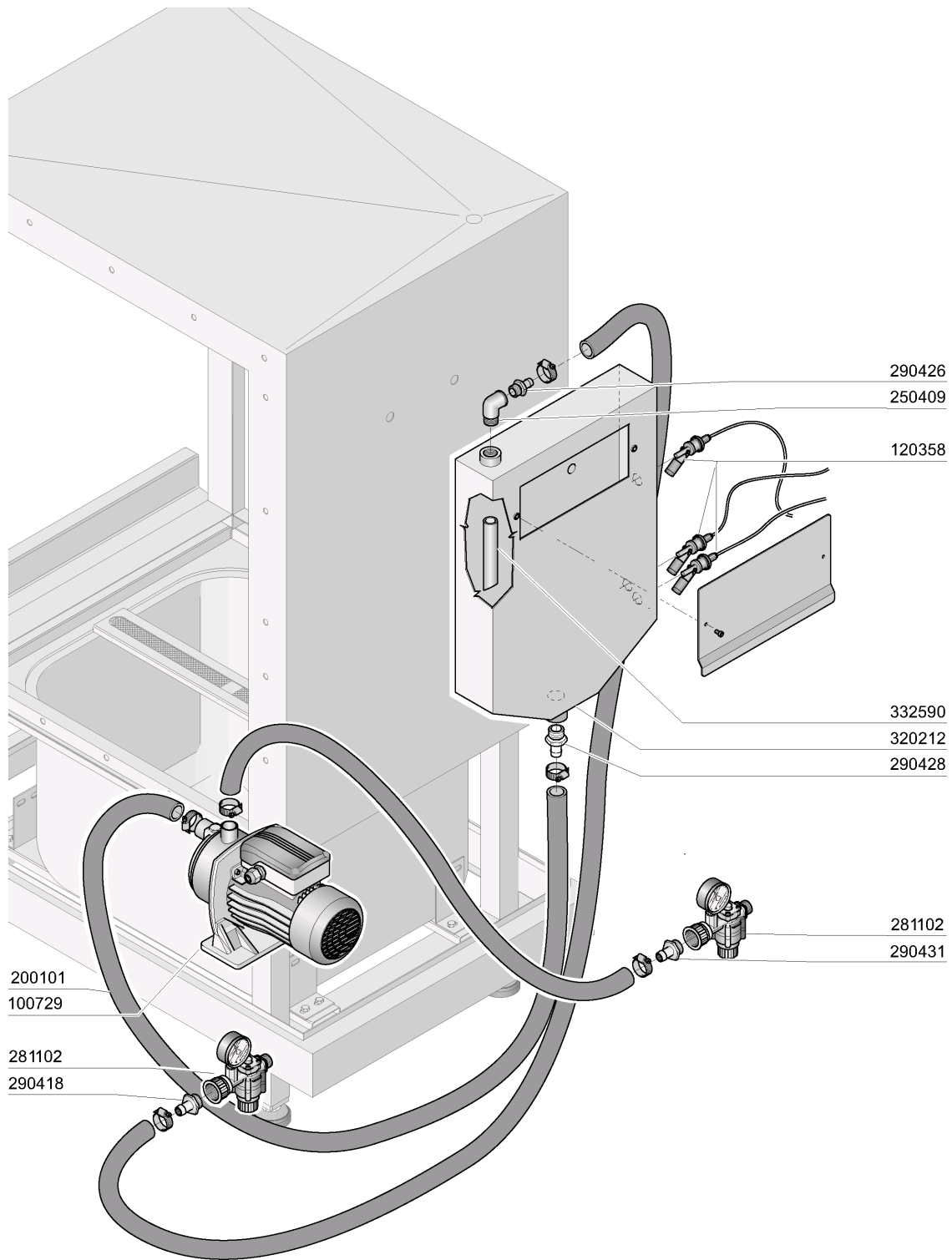

36 - Break tank_TR

CODE	DESCRIPTION
100729	PUMP HP 0,4 220/240V 2HM3T
120358	FLOATING MAGN.SWITCH
200101	RUBBER TUBE 25X35
250409	INOX ELL FF 1/2"
281102	1/2" ADJ VALVE C/W GAUGE TYPE
290418	NIPPLE 1/2"
290426	NIPPLE 1/2"
290428	NIPPLE M.3/4"
290431	NIPPLE 1/2"
320212	BREAK TANK BOX
332590	STAINLESS STEEL HOSE FOR B.T.

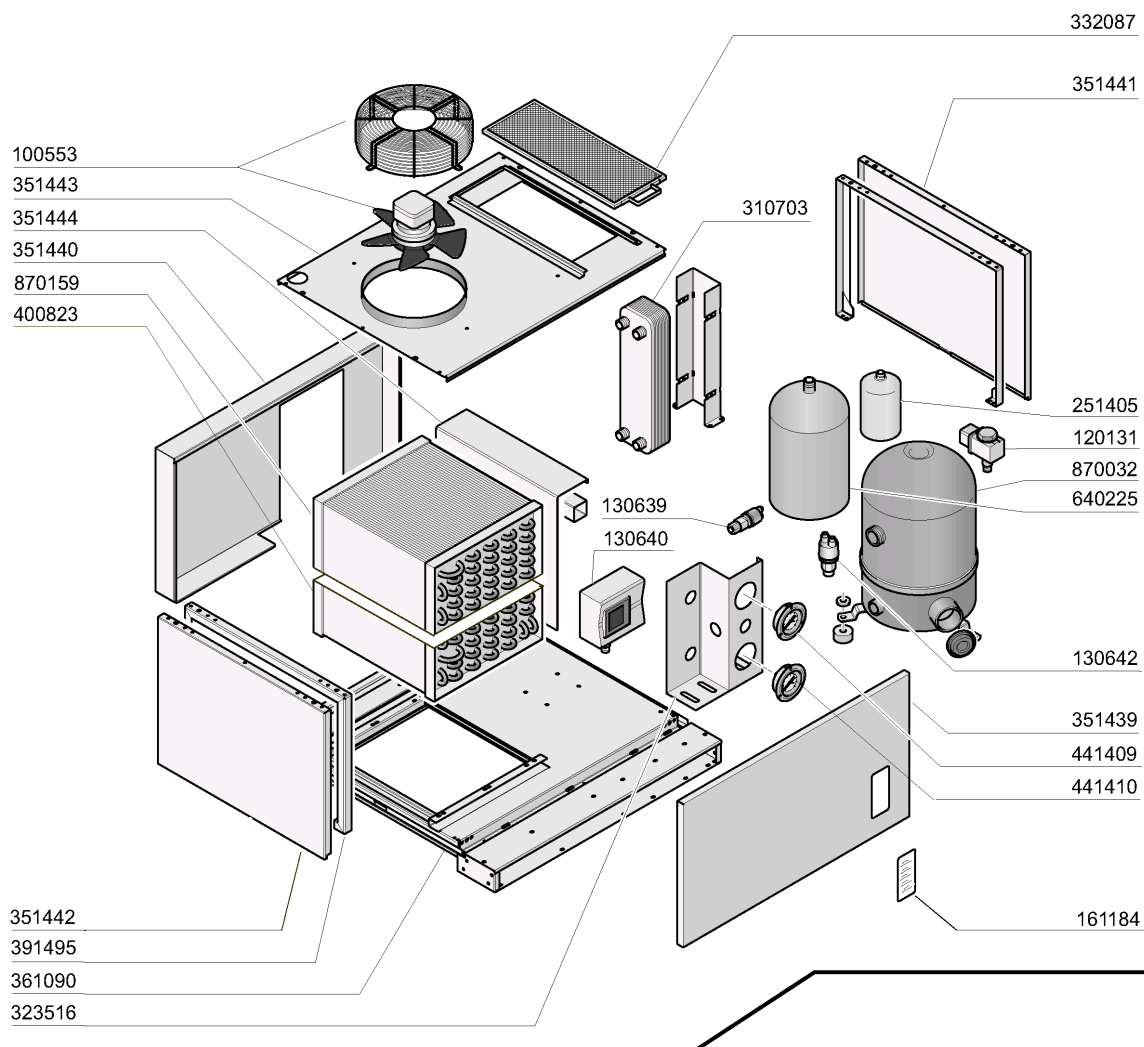

- ① - A x B x C = 298 x 423 x 490 = CODE 870159/RIV
- ① - A x B x C = 230 x 400 x 450 = CODE 870159
- ② - D x E x F = 142 x 490 x 423 = CODE 400823/RIV
- ② - D x E x F = 140 x 450 x 450 = CODE 400823

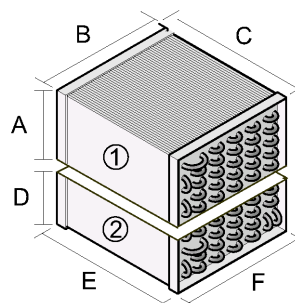

37 - Heat pumps WP4

CODE	DESCRIPTION
100553	WP4 FAN
120131	SOLEN. L182Q31-ZB10A 1/2"24V
130639	LOW PRESSURE SWITCH WP
130640	HIGH PRESSURE SWITCH WP
130642	PRESSURE SWITCH WP4-LOW PRESS.
161184	MANOMETER INSPECTION GLASS
251405	FILTER WP4
310703	RINSE WATER CONDENSOR
323516	MANOMETER SUPPORT
332087	WP4 COVER FILTER
351439	FRONT PANEL 750 MM
351440	BACK PANEL 750MM
351441	ENTRY PANEL 750MM
351442	EXIT PANEL 750MM
351443	UPPER PANEL 750MM
351444	PARZIALIZZATORE WP 750MM
361090	BASEMENT WP4
391495	LEFT SIDE HOOD
400823	BATTERY WP4
400823/RIV	BATTERY WP4
441409	MANOMETRO ASPIRAZIONE (WP)
441410	MANOMETRO CONDENSAZIONE (WP)
640225	LIQUID GAS CONTAINER FOR WP4
870032	COMPRESSOR WP4
870159	EVAPORATOR WP4
870159/RIV	EVAPORATOR WP4

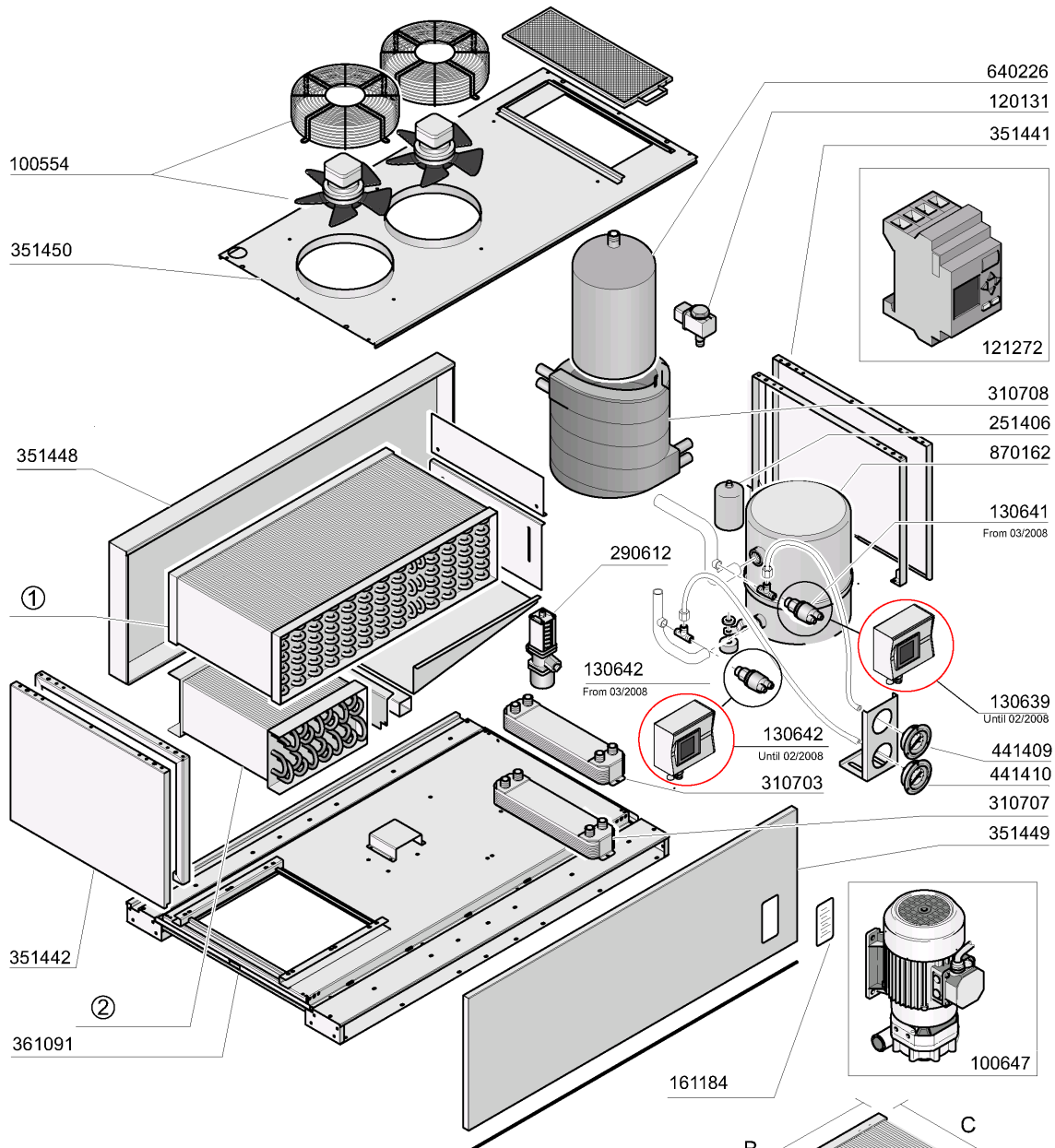

- ① A x B x C = 250 x 800 x 460 = CODE 870164/RIV
- ① A x B x C = 175 x 750 x 450 = CODE 870164
- ② D x E x F = 190 x 460 x 460 = CODE 400824/RIV
- ② D x E x F = 175 x 450 x 450 = CODE 400824

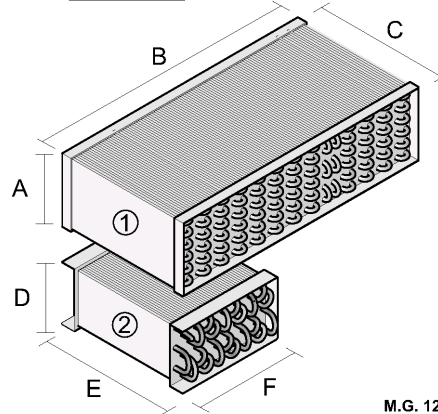

M.G. 12/09

38 - Heat pumps WP6

CODE	DESCRIPTION
100554	WP6/WP8 FAN
100647	PUMP HP 0,20 220/240/3 4226
120131	SOLEN. L182Q31-ZB10A 1/2"24V
121272	PLC
130639	LOW PRESSURE SWITCH WP
130641	PRESSOS WP4 LOW PRESS 2.2 BAR
130642	PRESSURE SWITCH WP4-LOW PRESS.
161184	MANOMETER INSPECTION GLASS
251406	FILTER WP6-WP8
290612	VALVOLA PRESSOSTATICA(WP6-WP8)
310703	RINSE WATER CONDENSOR
310707	CONDENS.GAS/ACQUA BY-PASS (WP)
310708	CONDENSER (WP)
351441	ENTRY PANEL 750MM
351442	EXIT PANEL 750MM
351448	BACK PANEL 1250MM WP
351449	1250MM WP FRONT PANEL
351450	UPPER PANEL 1250MM
361091	BASEMENT WP6
400824	BATTERY WP6
400824/RIV	BATTERY WP6
441409	MANOMETRO ASPIRAZIONE (WP)
441410	MANOMETRO CONDENSAZIONE (WP)
640226	LIQUID GAS CONTAINER FOR WP6-8
870162	COMPRESSOR WP6
870164	EVAPORATOR WP6
870164/RIV	EVAPORATOR WP6

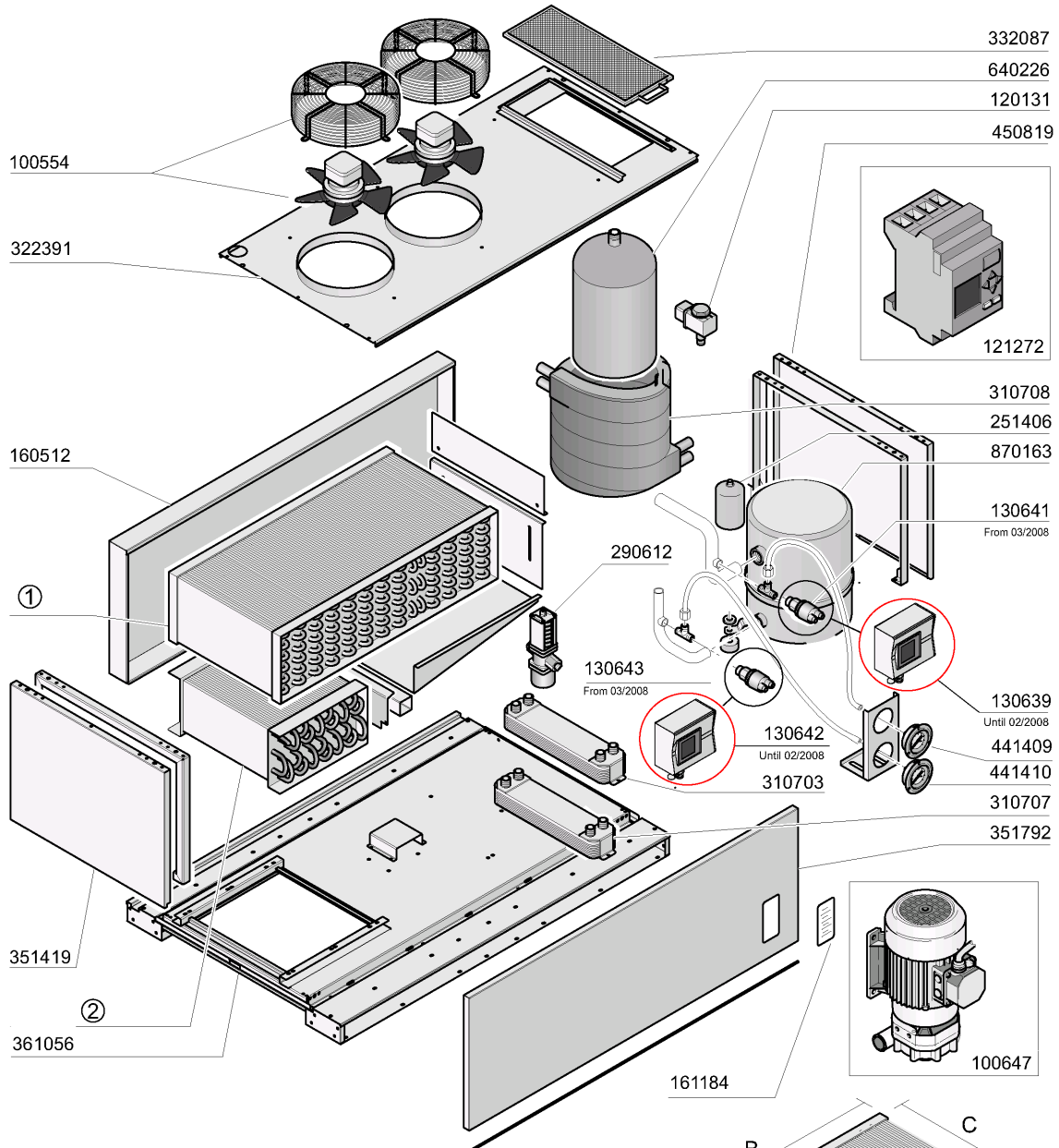

- ① A x B x C = 250 x 800 x 460 = CODE 870165/RIV
- ① A x B x C = 175 x 750 x 450 = CODE 870165
- ② D x E x F = 190 x 460 x 460 = CODE 400825/RIV
- ② D x E x F = 175 x 450 x 450 = CODE 400825

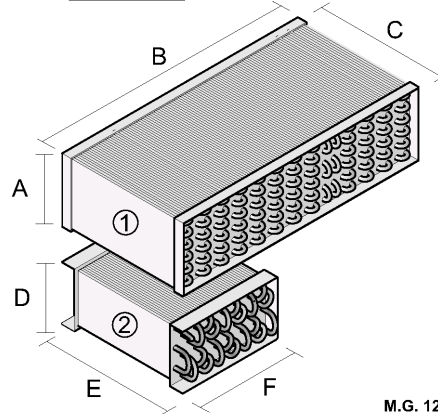

M.G. 12/09

39 - Heat pumps WP8

CODE	DESCRIPTION
100554	WP6/WP8 FAN
100647	PUMP HP 0,20 220/240/3 4226
120131	SOLENOID L182Q31-ZB10A 1/2"24V
121272	PLC
130639	LOW PRESSURE SWITCH WP
130641	PRESSOS WP4 LOW PRESS 2.2 BAR
130642	PRESSURE SWITCH WP4-LOW PRESS.
130643	HIGH PRESSURE PRESS.SWITCH WP
160512	SPACER 35,5
161184	MANOMETER INSPECTION GLASS
251406	FILTER WP6-WP8
290612	VALVOLA PRESSOSTATICA(WP6-WP8)
310703	RINSE WATER CONDENSOR
310707	CONDENS.GAS/ACQUA BY-PASS (WP)
310708	CONDENSER (WP)
322391	PANNELLO SUPERIORE WP 1500MM
332087	WP4 COVER FILTER
351419	FRONT PANEL WP
351792	PANNELLO ANTERIORE WP NE2
361056	BASEMENT WP8
400825	BATTERIA PRERISCALD.ACQUA(WP8)
400825/RIV	BATTERY WP6
441409	MANOMETRO ASPIRAZIONE (WP)
441410	MANOMETRO CONDENSAZIONE (WP)
450819	STAINL.ST SCREW M6
640226	LIQUID GAS CONTAINER FOR WP6-8
870163	COMPRESSORE POMPA WP8
870165	EVAPORATOR WP8
870165/RIV	EVAPORATOR WP8

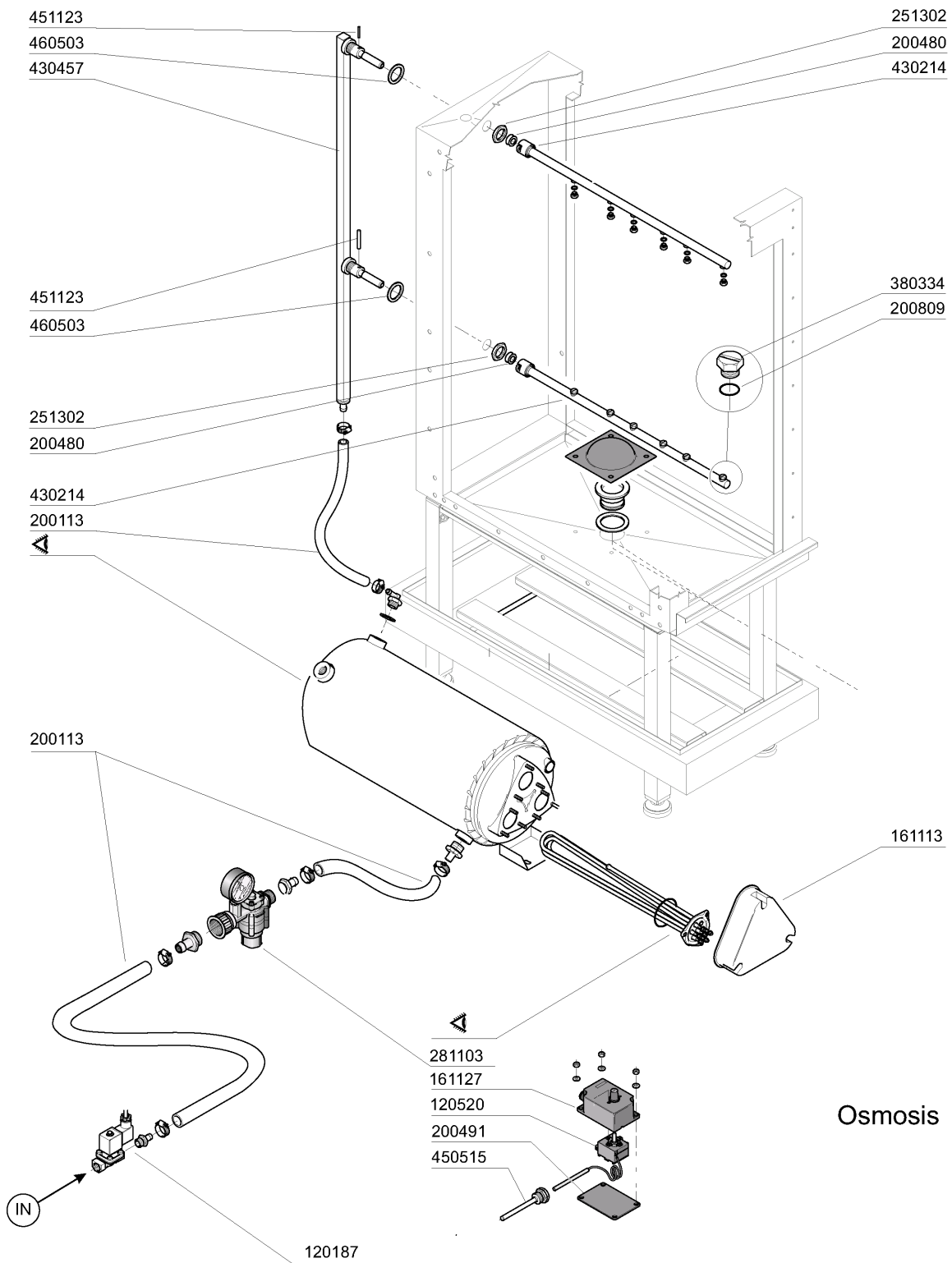

Osmosis

M.G 01/09

CODE	DESCRIPTION
120187	SOLENOID VALVE 3/4" 24V
120520	SECURITY THERMOSTAT 110-130Ø
161113	ELMENT COVER BLACK
161127	BOX FOR THERMOSTAT
200113	RUBBER HOSE 12 X 22
200480	GASKET F. RINSE CONNECT.
200491	BACK GASKET OF THERMOSTAT BOX
200809	OR GASKET 1,78X8,73X12,29
251302	S/S LOCK NUT 3/4" AC-ACR
281103	ADJ. VALUE
380334	JET
430214	RINSE ARM NE02
430457	RINSE COLUMN NE02
450515	STAINL.ST.SHIELD FOR 1 THERMOS
451123	ELASTIC PIN 4X16
460503	SEALING WASHER 38X27X2(3/4)